

Thank you for purchasing the Radiomaster ER6GV ExpressLRS receiver. The ER6GV receiver is based on the revolutionary ExpressLRS system. It offers high performance, high reliability, flexible configuration, fast response speed and ultra-long range. The ER6GV Receiver has a built in Vario for use in gliders.

Important:

1. The recommended ELRS LUA settings on the remote-control end are:

- **Standard servos:**

Packet Rate:	100Hz Full
Telem Ratio:	Std (1:8) (default if unsure)
Switch Mode:	8ch

- **Performance servos:**

Packet Rate:	333Hz Full
Telem Ratio:	Std (1:8)
Switch Mode:	8ch

- The maximum input voltage for the EXT-V (external voltage input) telemetry reading is 35V. Do not exceed 35V or the receiver will be damaged.
- The EXT-V (external voltage input) of the ER6GV is accessed via the EXT-V solder pad on the PCB. A single wire must be soldered to this pad and connected to the positive wire of the battery or ESC. If no EXT-V power source is found, the ER6GV will default to reading the voltage on the receiver pins, only one voltage input can be used at the any given time.
- Calibration of the telemetry voltage will be required on your radio. Navigate to the telemetry page on your radio and locate the Rx/Bt sensor. Edit the sensor settings and adjust the offset until the displayed reading matches the actual voltage of the battery in the model. If there is a large difference, adjustment of the ratio may also be required.
- Channel 6 on the receiver must not be used as the power input channel and may out be used as a servo output channel. Power from an ESC or Receiver battery must only be applied on Channels 1 to 5.

*For best results, calibrate the voltage of your radio using a fully charged battery of the correct cell count intended for use in the model.

TELEMETRY	11/12	SENSOR 11	7.3V
8: TRSS	-28dB	Type	Custom
9: TQly	100%	ID	0008 1
10: TSNR	15dB	Source	Internal
11: Rx/Bt	7.0V	Unit	V
12: Curr	0.0A	Precision	0.0
13: Capa	0mAh	Ratio	-
14: Bat%	0%	Offset	0.0

6: ExpressLRS Arming requirements and the use of Channel 5: CH5 is required by ExpressLRS to set the Arm state of the RF module in your radio. It is recommended to assign CH5 to a switch such as your throttle cut switch as this will provide benefits such as dynamic. Using the ExpressLRS LUA or the Wifi WebUI, you can assign different channels to the CH5 output of your receiver. See example to the right:

- CH1: CH1
- CH2: CH2
- CH3: CH3
- CH4: CH4
- CH5: CH7
- CH6: CH6

Please visit <https://www.expresslrs.org/> to learn more on the importance of setting up arming.

The Radiomaster ER6GV receiver has been specially designed for glider pilots who require a compact and slim receiver with a built in vario function. It can drive up to 6 servos and has built-in receiver voltage telemetry and flight battery telemetry with the ability to automatically detect which voltage input to use. The ER6GV features a dual-antenna with telemetry power up to 50mw. The ER6GV can work stably with a 1S Lipo receiver battery.

Product Features:

- Power supply: DC 3.5 - 8.4V
- Antenna type: 15cm high sensitivity antenna
- Wireless protocol: ExpressLRS 3.3.0 pre-installed
- Output channel: 6CH PWM
- Telemetry power: maximum 50mw (LUA Adjustable)
- Built-in high-precision air pressure sensor (Vario)
- Battery voltage detection range: DC 3.0 - 26V
- Weight: 5.0 grams
- Dimensions: 42*13*8mm

Firmware:

- Device Category: Radiomaster 2.4Ghz
- Device: RadioMaster ER6G/ER6GV 2400 PWM RX

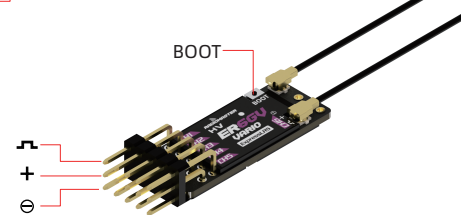
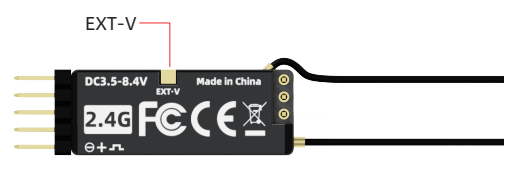
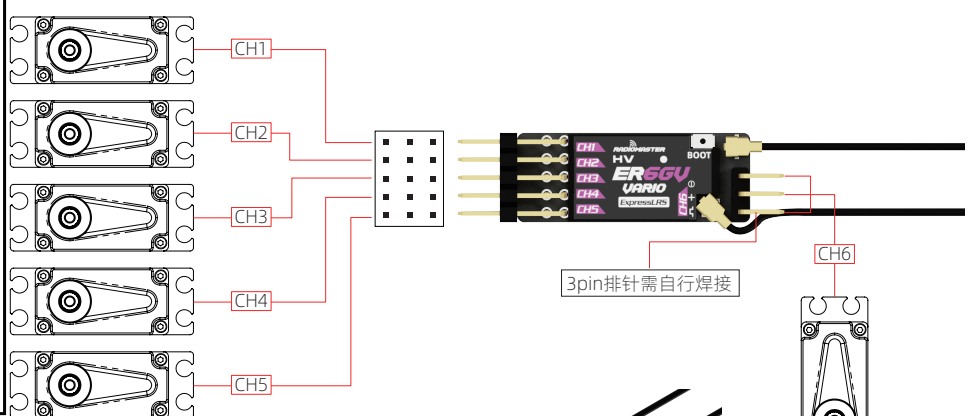

Binding method (Traditional):

- The first time you power on your receiver, the LED will double blink. This indicates that the receiver is in bind mode. If this is not the case, hold down the boot button for 10 seconds to reset the receiver.
- Open the ExpressLRS LUA on your remote controller and select [BIND], then confirm.
- A successful bind is indicated by the light being a steady on, indicating that frequency binding was successful.



Note: To bind the receiver a second time or to another radio, power cycle the receiver 3 times. On the third power cycle, the LED will double blink indicating bind mode. If you cannot successfully enter bind mode with the 3 power cycle method, you can hold down the boot button for 10 seconds to reset the receiver to bind mode or use the passphrase method below.

WARNING: All previous settings in the receiver will be erased and need to be set again when using the reset button.

Binding method (Passphrase):

- Open the ExpressLRS LUA and navigate to the Wifi Connectivity page. Select the Enable Wifi option and connect to your radios wifi with a mobile phone, tablet or PC (See TX Wifi notes below). Open the WebUI (Express LRS web page on <http://10.0.0.1/>) and choose a unique bind phrase. Note Bind phrases are not secret and can be read. Save and Reboot.
- Power up the receiver and wait 60 seconds for the LED to blink rapidly to indicate Wifi mode. Connect your phone, tablet or PC to the receivers Wifi (See TX Wifi notes below). Open the WebUI (Express LRS web page on <http://10.0.0.1/>) and enter the matching bind phrase previously entered on your radio. Note Bind phrases are not secret and can be read. Save and Reboot. Once a radio and a receiver have the same bind phrase set they will automatically bind.

TX Wifi notes:	RX Wifi notes:
WiFi default network name: ExpressLRS TX	WiFi default network name: ExpressLRS RX
WiFi default password: expresslrs	WiFi default password: expresslrs
Default URL: http://10.0.0.1/ (Open in browser)	Default URL: http://10.0.0.1/ (Open in browser)