

# Scorpion Tribunus III (6 Cell) ESC SBEC Series

## Tribunus III 06-80A / III 06-110A / III 06-160A User guide



### SAFETY

- Scorpion and their re-sellers are not responsible for your use of this product, or sustained damage or injury as a result of its usage.
- Understand that an electric motor that is connected to a battery and Electronic Speed Controller (ESC) may start unexpectedly and cause serious injuries. Always treat them with necessary respect. Keep the propeller away from your body and others at all times.
- We suggest that you remove the propeller when you are working on an airplane with the battery connected.
- We suggest that you remove the pinion when working on a Helicopter with the battery connected.
- Please observe all local laws regarding the flying of UAV (Unmanned Aerial Vehicle) aircraft.
- Never fly over others or near crowds.

### Included in the Box

- 1 x Tribunus III ESC (SBEC)
- 1 x Master and Slave BEC cable
- 1 x Cooling Fan (except III 06-80A)
- 1 x Mounting Hardware Set
- 1 x Thank you card

### Features of Tribunus III ESC SBEC

1. All new PCB design with improved heat transfer techniques for reducing operational temperature, and improving the power rating of the ESC.
2. High Strength BEC with programable voltage range from 5V – 12V / OFF (see page #2 for specifications)
3. Dedicated Cooling Fan port with temperature controlled enabling.
4. Aluminum Heat Sink and case with mounting tabs and Fan mounting holes.
5. Wide input Voltage range (see page #2 for specifications)
6. 32-bit processor enable superb protection features such as over current, over voltage (limitations apply), de-mag / de-sync, temperature protection, etc
7. Dynamic Frequency / Dynamic Timing – Auto adjust in real time to provide peak efficiency and torque in all situations.
8. Build in phase sensor (RPM sensor) on the slave cable signal wire for connecting to external governors, or monitoring RPM via Telemetry
9. High Current, with over current protection
10. Built in temperature sensor with adjustable temperature protection
11. Airplane / Airplane with Reverse / Helicopter Modes. Stored / Unstored Governor Mode, External Governor Mode.
12. Utilizes Morse Code for Communication / Error Warnings
13. Full Telemetry read out with compatible devices such as Mikado Vbar Control, Futaba, Jeti or to many other systems (with 3rd party converters or to any micro controller via Unsolicited Telemetry Protocol) (email [support@spihk.com](mailto:support@spihk.com) for more information).
14. Full Data Logging which can be pulled from the ESC and saved / exported (.CSV)
15. Downloadable PC program and Android Apps
16. PC Connectivity / Android Connectivity (OTG cable needed), with USB C cable. Or connect via Vlink II cable + Diode adaptor cable (sold separately)
17. Programable via Mikado Vbar Control Radio (Scorpion Telemetry cable required)
18. Upgradeable Firmware (using Sprout Software)

## ESC Specifications

Model Type	Tribunus III 06-80A	Tribunus III 06-110A	Tribunus III 06-160A
Lipo Battery	11-26.1 Volts	11-26.1 Volts	11-26.1 Volts
Current Rating (Continuous / Peak)	80A/ 110A Peak	110A/ 150A Peak	160A/ 200A Peak
BEC Voltage Range	Programable - OFF / 5.0 / 6.2 / 7.2 / 8.4 / 8.8 / 10.0 / 11.0 / 12.1 Volt		
BEC Rating (Continuous / Peak)	8A / 12A Peak	10A / 20A Peak	15A / 30A Peak
Resistance	0.45mohms *2	0.45mohms *2	0.37mohms *2
Weight (with wires)	70.0g	105.0g	150.0g
Size	32.0 x 20.3 x 52.2 mm	32.0 x 23.1 x 52.2 mm	36.8 x 29.6 x 75.3 mm
Mounting Tab Dimensions	4 x M2.5 58.0 x 16.0 (batt side) / 24.0 (motor side) mm		4 x M3 84.0 x 24.0 mm
Temperature controlled Fan	Available (programmable)		
Program Cut Type	from 30-100%		
Cut off delay	1000ms-65000ms		
Protection Features	<b>Adjustable Protections:</b> Temperature, Voltage, Current, Capacity <b>Fixed Internal Protections:</b> Temperature (maximum), De-Sync, De-Mag, Phase Current, etc.		
Airplane modes	Airplane Mode / Airplane with Reverse Mode		
Drag Break	Available on Airplane Mode only		
Acceleration Speed	100ms-1000ms		
Active Free Wheeling (PWM mode)	Always on for Helicopter Mode, selectable for Airplane mode		
Heli Gov Mode	Scorpion Internal Gov / VBAR Gov / External Gov		
Soft Start	Only Available on Heli Mode		
Acceleration Speed	Fast, Medium, Slow, Custom Programable		
Bail out mode	Fast, Medium, Slow, Custom Programable		
Governor Gains	Available on Heli mode: Soft, Default, Hard, Custom		
Rotation	CW / CCW programmable		
Timing	5deg - 30 deg Dynamic Timing		
Frequency	8kHz - 32kHz Dynamic Frequency		
Data Logging	RPM, Throttle %, Voltage, Current, Temperature, Output Power, Mah, Errors		
Data Logging Export Format	.TGB (sproto) / .CSV		
Telemetry Communication Protocol	Mikado VBAR / Futaba SBUS 2 / Jeti EX Bus / Unsolicited		
Input Signal (Master Cable)	1000µs - 2000µs PWM (programable)		
Phase (RPM) Signal	Available (Signal wire of Slave Cable)		
MAX RPM	240,000 Electrical RPM		

# 1.0 Connecting your ESC

\*Please refer to the diagram on the next page to properly connect your ESC.

## 1.1 Add your battery connector

You must attach a suitable battery connector of your choice to the red (positive) and black (negative) power wires. Mount the battery connector to the wires. ENSURE THAT THE POLARITY IS CORRECT (red wire (positive) to battery red wire (positive), black wire (negative) to battery black wire (negative)). **This ESC does not have reverse polarity protection, and plugging in reverse polarity will damage and void your ESC warranty.**

**NOTE:** Do not add excessive length of wire between your Battery and ESC without proper precautions. Doing so without the required precautions can cause voltage fluctuations which may damage your ESC and void the warranty. See more info in Section 16.

## 1.2 Connect Motor to ESC

We recommend using bullet connectors to connect your ESC to your motor as most of the Scorpion motors come with pre-installed bullet connectors that include a female set for your ESC. Solder the corresponding connectors for your motor to the phase wires coming from the ESC, or solder the phase wires directly to the motor leads. ESC direction can be simply reversed in ESC programming. Once connected DO NOT allow any exposed wire or connectors to contact each other! Ensure that a proper insulation material (such as heat shrink) is around each of the three wires. Failure to do so will cause the ESC to malfunction and void your warranty.

**NOTE:** If your Motor must be placed far from the battery, it is better for the excessive wire length to be between the ESC and the Motor, rather than the Battery and ESC. If doing this, then ensure the phase wires are equal length, and not wrapped around each other.

## 1.3 Connect to your Receiver / External Governor / Telemetry Port

**Master BEC Port** (Master Cable = a red plastic connector) = Throttle Signal + BEC power

- Connect to Throttle Channel on RX / Gyro

**Slave BEC Port** (Slave Cable = a black plastic connector) = RPM Signal + BEC Power

- Connect to External Governor / RPM port. (Ensure the RPM port is suited to take BEC power, and if not, separate the +/- cables from the signal wire, and plug them into another port).
- You may unplug the yellow (signal) wire on the slave cable if you do not use the RPM signal for telemetry or external governor.

**If you have external flight system battery, then you can disable the BEC in programming.**

**PC Port (data port)** = Telemetry Data

- Depending on your Transmitter System / Gyro used, the cabling used to connect, will be different.
- Mikado VBC radio system use a specific Scorpion Telemetry Cable
- Other radio systems (Futaba / Jeti) use different Cable for connection (See Futaba and Jeti Telemetry Guides for more details)
- Some FBL/ Radio system, use only the signal wire from the PC port (brain / ikon)
- Please be sure to research about the telemetry protocol for your specific Transmitter system if you are unsure.

## 1.4 Mounting / Connect the Cooling Fan

- Using the provided cooling fan is HIGHLY recommended. Without the cooling fan the continuous current rating of the ESC will be reduced up to 25%!
- Mount the cooling fan to you ESC with the provided screws. Use blue Loctite into the threads on the ESC case, and do not overtighten.
- Connect the cooling fan to the FAN port as labeled on the ESC
- We recommend to use only our Scorpion High Power Cooling Fans with these ESCs
- Cooling fan has 2 wires (+/-) and operates off the BEC / RX voltage (the stock fan is rated for 8.4V maximum! If using the higher BEC voltages you need to purchase the 12V capable cooling fan!)
- Pay attention to the plug orientation. If you plug the fan with the black wires toward the switch symbol, it will be temperature controlled. If you plug the black wire towards the ground (-) symbol, the fan will be always on.

## 1.5 Mounting the ESC

Mount the ESC in an area of your model which has access to airflow with the Heatsink side of the controller facing outward. We recommend using the integrated mounting tabs with included hardware to attach to the airframe for secure mounting and easy removal.

## 1.6 Tribunus ESC BEC

For safety reasons we recommend using a Scorpion backup guard II. The Backup guard can be used on any BEC voltage from 5.1 to 12.1V. Make sure that the Backup guard II Lipo is charged. Also make sure all used RC components are designed to run at the set BEC voltage.

**NOTE:** The induction voltage cause by some servos on the market could activate the protection of the BEC. Unless 8.4V (or 12.1V if using 12V servo) is specifically required, we highly recommend the BEC voltage set to 7.2V (or 11.0V if using 12V servos) or below to avoid any issues with this possible servo issue. <http://www.scorpionsystem.com/blog/?p=7173>

# 1.1 ESC Connections

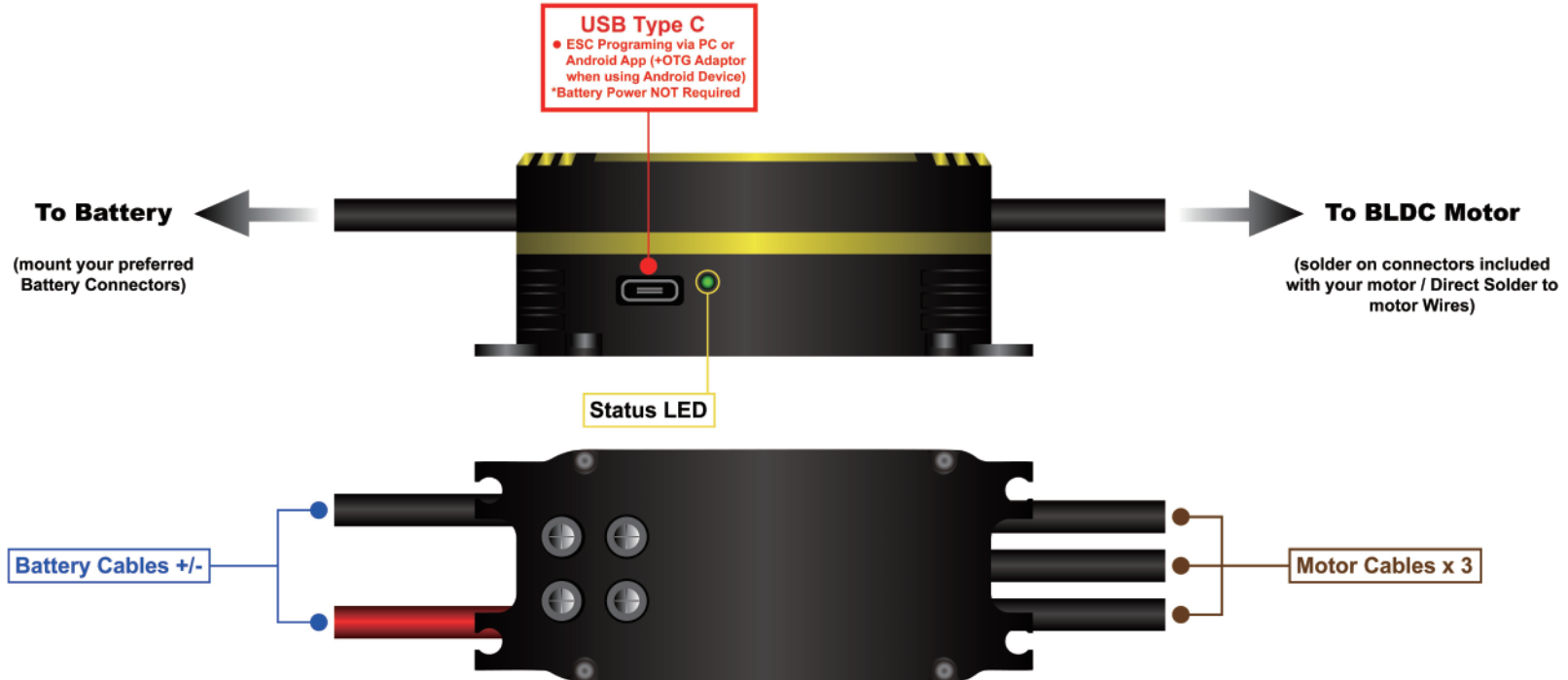
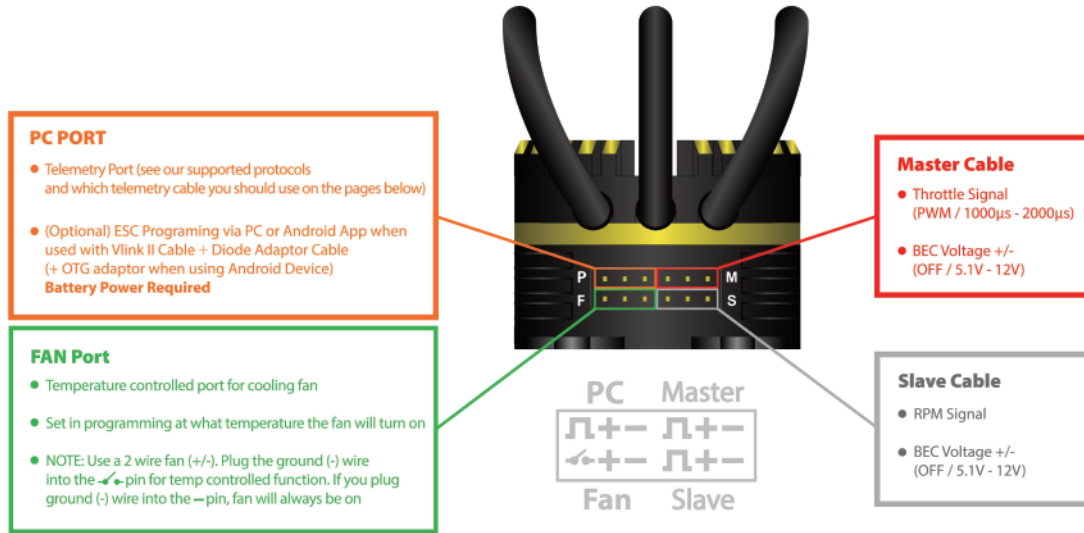

## 2.0 Default Parameters / Initial Setup

### 2.1 Before you plug in

- 2.1.1 Ensure that your ESC is connected to the proper channel on your receiver.
- 2.1.2 Ensure your battery connectors are mounted properly, and that you plug in with the correct polarity.
- 2.1.3 Ensure you throttle channel is programmed correctly in your radio and you have a clear understanding of all throttle hold, endpoints, signal directions.
- 2.1.4 Ensure your Radio System and Servos can accept the default **6.2V BEC** voltage.
- 2.1.5 **When you plug in the ESC, you should expect a “Spark” upon contact. The BEC / RX system will not immediately boot up as the ESC runs system safety checks prior to powering on. The BEC and ESC will only power on after a few seconds.**
- 2.1.6 When ESC powers on it will beep the motor and flash the LED on the side with the “Power on Sound” (POS)
  - Power on Sound spells “Voltage” in Morse Code

### 2.2 Default Parameters

- 2.2.1 Please note the Tribunus III ESC’s come with a default Helicopter setup out of the box.
- 2.2.2 If desired you can quickly change to Default Airplane Mode using stick programming. See **Section 2.4** for more information.

	Heli Default	Airplane Default
<b>Mode:</b>	Un-stored Helicopter Governor	Airplane Mode
<b>BEC:</b>	5.0 Volts	
<b>Communication Protocol:</b>	VBAR Telemetry Protocol	Unsolicited Telemetry Mode

**\*\*Full list of detailed Settings / Protection Setting are listed on the following pages.\*\***

- 2.2.3 If you are using **Mikado VBAR control radio** you can skip many of the below steps, (including Throttle Calibration) and program completely the ESC from your VBC.

### 2.3 Throttle Calibration

You **MUST** perform throttle range calibration before the first use of the ESC, except if you are using VBAR external governor mode. Remove propeller/pinion from motor or back of pinion from main gear while performing initial throttle range calibration.

**NOTE for Spektrum Users – You may need to power your RX separately with a separate RX battery during these calibration steps. This is because Spektrum RX output first the “fail safe” setting prior to binding, which can interfere with the calibration process.**

- 2.3.1 Turn on transmitter and power up receiver, then set throttle to maximum position be sure that your throttle curve is set at 0% minimum throttle and 100% at maximum throttle.
- 2.3.2 Connect the battery to the ESC. After few seconds you will hear **one** beep. Now move your throttle to the lowest position within a 3 second time period, then you will hear **two** beeps, and POS Morse code come from the motor. This mean your calibration is done. You only need to do this once as throttle range will be stored in the memory of the speed controller. You can reset the throttle range by performing steps 2.3.1 to 2.3.2 again.
- 2.3.3 If using Airplane with Reverse mode, there is additional Calibration Steps. Please see detailed instructions in **Section 18**.

### 2.4 Basic Stick Programing - Airplane Default Mode vs. Helicopter Default Mode

While it is advised to download and use our SPROTO PC / Android App for programing. We now have enabled the option to quickly switch between “Default Airplane Mode” and “Default Helicopter Mode” using simple stick programming.

- 2.4.1 Remove the propeller, or pinion from your motor.
- 2.4.2 Turn on transmitter and power up your receiver (**see note above if using Spektrum**), then set throttle to maximum position and be sure that your throttle curve is set at 0% minimum throttle and 100% at maximum throttle.
- 2.4.3 **Switching to Default Airplane Mode –** Plug the ESC in at full throttle. Leave the throttle stick at 100% until you hear 2 continuous beeps, then lower the throttle stick down to 0% within a 3 second time period then you will hear two beeps, and POS Morse code come from the motor, this mean your ESC has swapped to Airplane Mode.
- 2.4.4 **Switching to Default Helicopter Mode -** Plug the ESC in at full throttle. Leave the throttle stick at 100% until you hear 3 continuous beeps, then lower the throttle stick down to 0% within a 3 second time period then you will hear two beeps, and POS Morse code come from the motor, this mean your ESC has swapped to Helicopter Mode.

### 3.0 Download / Registration of SPROTO PC SOFTWARE

- Sproto is our program which supports all the Tribunus ESCs. After downloading the program and installing it, you need to register an account for firmware updates and configuring the settings.
- Make sure you download the latest version of Sproto from <https://sproto.net/#/>

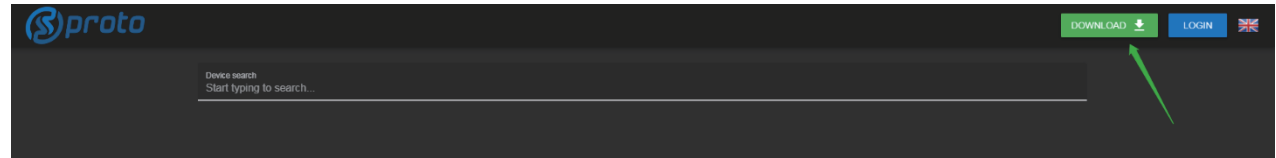

- If you do not already have a SPROTO Account, then please create one by clicking the "Register" button.
- **NOTE: This is NOT the same account from [www.scorpionsystem.com](http://www.scorpionsystem.com). You need a separate Sproto account.**
- After clicking the Register button, you will be able to set your User name, Email, Language, and Password.

A screenshot of the Sproto registration form. It features the 'proto' logo at the top left. Below the logo are two input fields for 'User name' and 'Password'. There is a 'Save password' checkbox. At the bottom, there are three buttons: 'Register' (highlighted with a red box and a red arrow), 'Restore', and 'Login'. A 'Cancel' button is also present.A screenshot of the Sproto registration form with the 'Language' dropdown menu open. The 'User name' field contains 'tribunususer01' and the 'Email' field contains 'scorpion@scorpion.com'. The 'Language' dropdown is currently set to 'English' and is open, showing a list of languages: Deutsch, English (highlighted), Español, Français, Italiano, 日本語, and 한국어. There are 'Password' and 'Confirm' fields below the language list, and a 'Login' link at the bottom left.

- After clicking "Register" we will send a one-time pass code to your listed email. Please wait a few minutes, and check your email for the code. Be sure to check your spam folder if you do not find the code in your inbox. If you do not receive the code, please try again, and if still you cannot receive the code, then please email us at [support@spihk.com](mailto:support@spihk.com)

A screenshot of the Sproto registration form for the verification step. It features the 'proto' logo at the top left. Below the logo are two input fields: 'Email' (containing 'scorpion@scorpion.com') and 'Code'. There is a 'Save password' checkbox. At the bottom, there are three buttons: 'Login', 'Confirm', and 'Cancel'.

- **NOTE:** Some email servers block emails from our server. There is nothing which we can do about this. Please try another email, or email us at [support@spihk.com](mailto:support@spihk.com) and we can help you create and account manually.

## 4.1 Download the Prolific USB Driver and/ or CH341SER Driver

The drivers **SHOULD** automatically download when you connect the ESC to the PC via the USB-C cable. Make sure you PC is connected to the internet so the drivers may download, and you may need to wait some time for the installation to complete automatically.

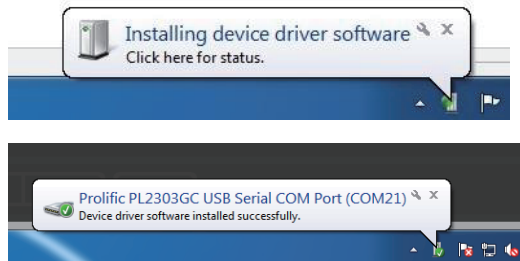

**If the drivers do not automatically install you can check the below steps for manual installation.**

Click TOOLS-> EXTERNAL TOOLS -> then look to see if you have the 2 x drivers installed, signified by the Green Check mark. If not installed, you will need to click on the Blue Hyperlink, and install them.

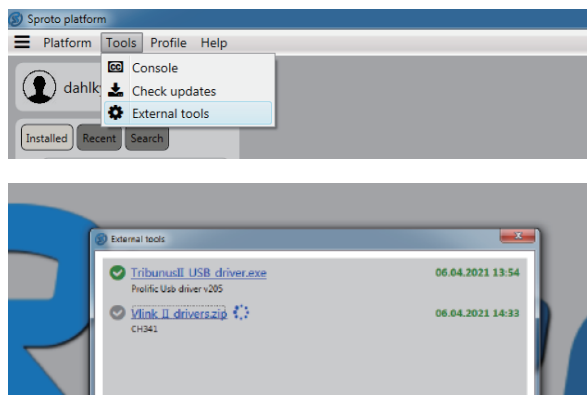

- The Prolific USB Driver is needed if you will connect with the USB cable to your ESC.
- The Vlink II CH341 Driver is needed if you will use the VlinkII cable + Diode Cable.

The Prolific USB driver is directly a .exe file which will automatically open and run.

### VLINK II CH341 Note

With VLINK II CH341 driver you will need to download the zip file, then click into CH341SER -> SETUP.exe, then follow the on-screen instructions.

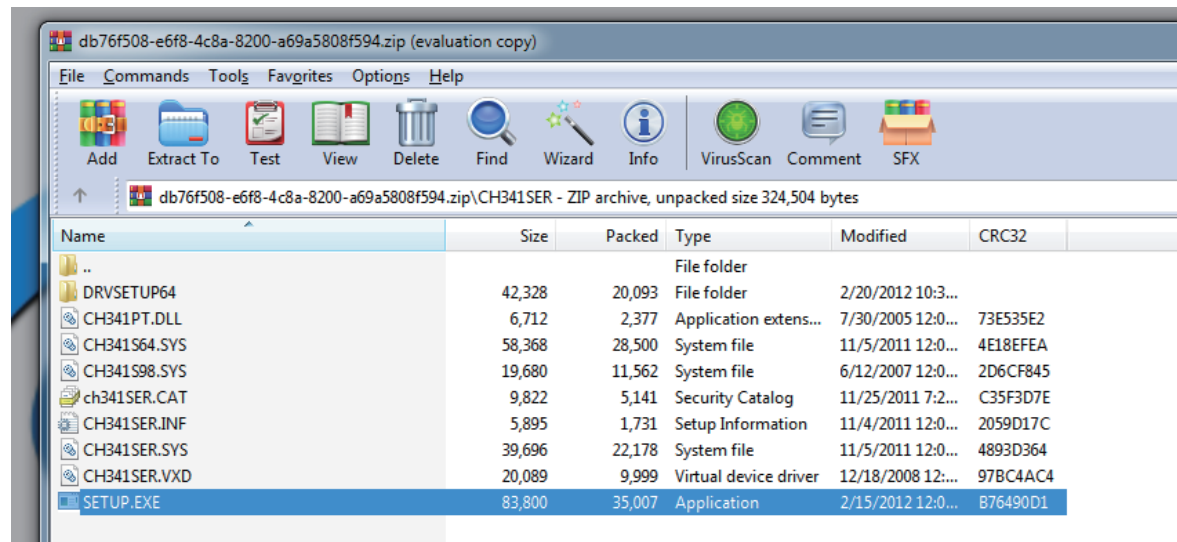
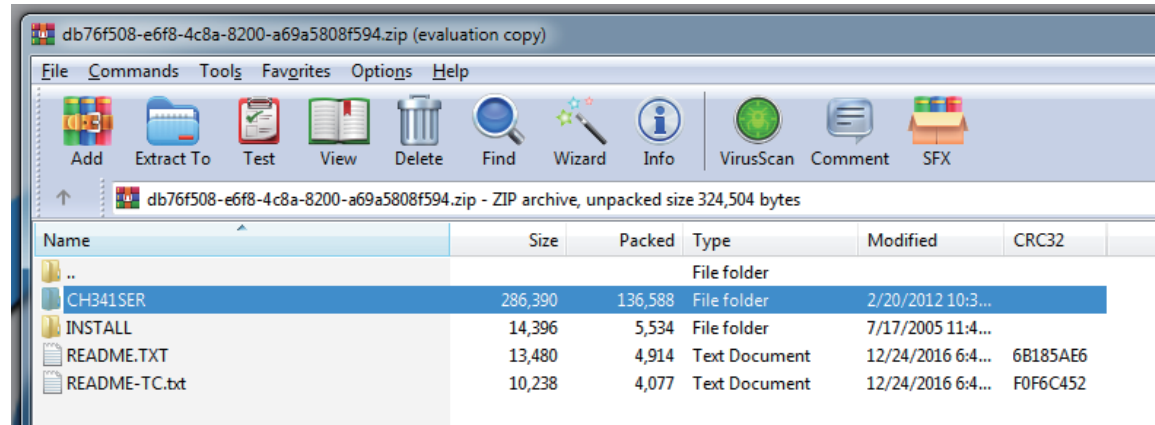

## 4.2 (Optional) Download the Tribunus Configurator from Google Play Store

If you use an OTG converter cable, then you can connect the Tribunus to your Android Device and program the ESC from the Tribunus Configurator App from the Google Play Store. Open the App, and when you plug in the ESC to the device (with OTG cable) then the ESC will automatically connect to the app. The app follows the same structure as the Sproto PC program and can be navigated easily.

<https://play.google.com/store/apps/details?id=en.scorpion.tribunusapp&hl=en&gl=US>

# Tribunus III ESC cofigurator

SCORPION POWER SYSTEM LTD

5+ Downloads | 3+ Rated for 3+ Ⓞ

HK\$78.00 Buy

Share

Add to wishlist

You don't have any devices

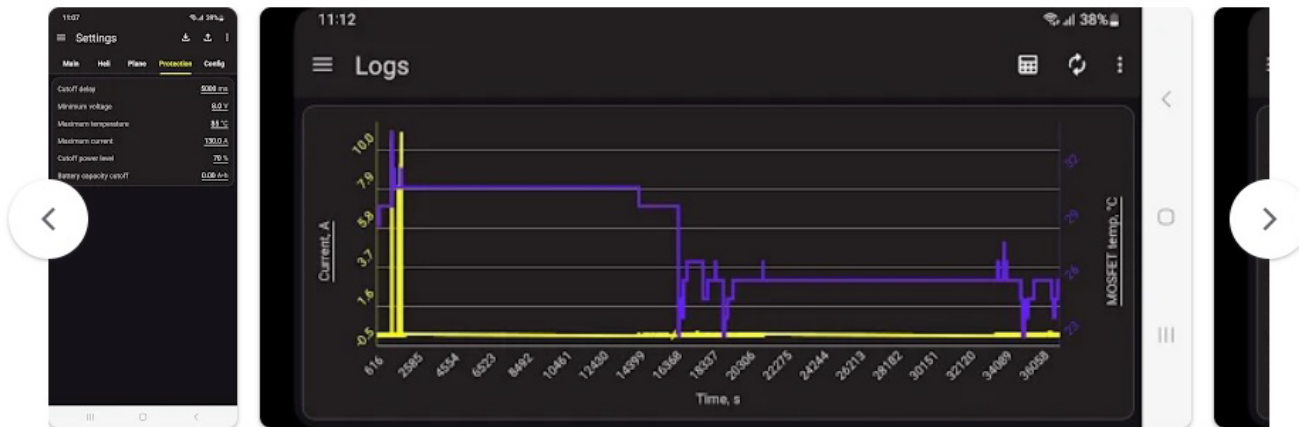

App support ▾

## 4.0 Connecting your ESC for Programing

### **Option 1:** USB CONNECTION

- Battery Power Not Required
- USB Cable will power up MCU and allow programing / Downloading the logs
- Be sure to use a DATA USB Cable, not a cheap power only USB cable

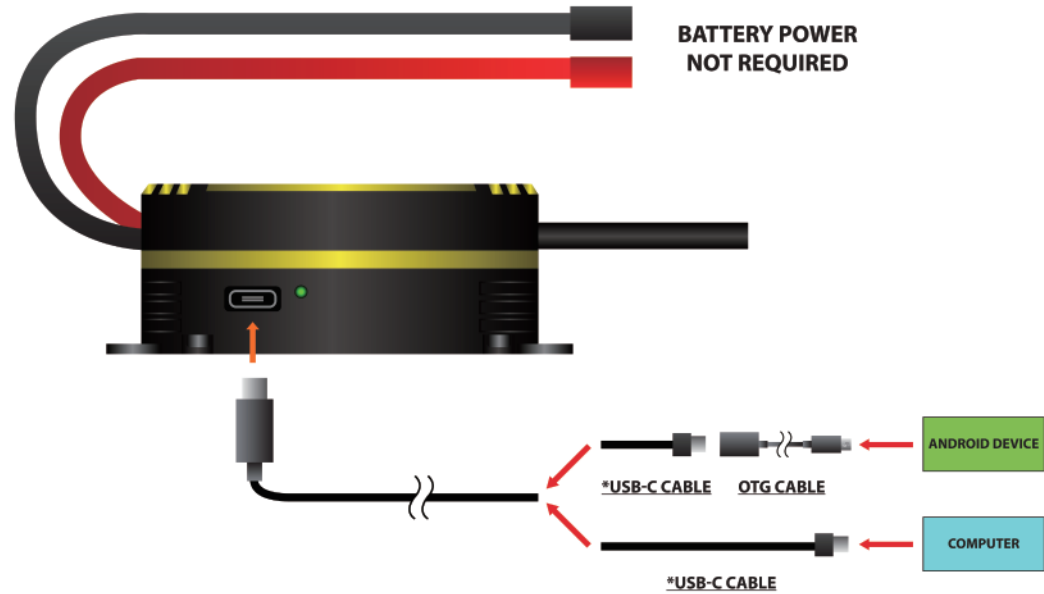

\*Be sure to use a data cable, not a cheap power only cable.

### **Option 2:** VLINK II CONNECTION

- Battery Power Required
- You must use the diode cable between your esc and the Vlink II Cable. Otherwise you risk to damage your USB Port

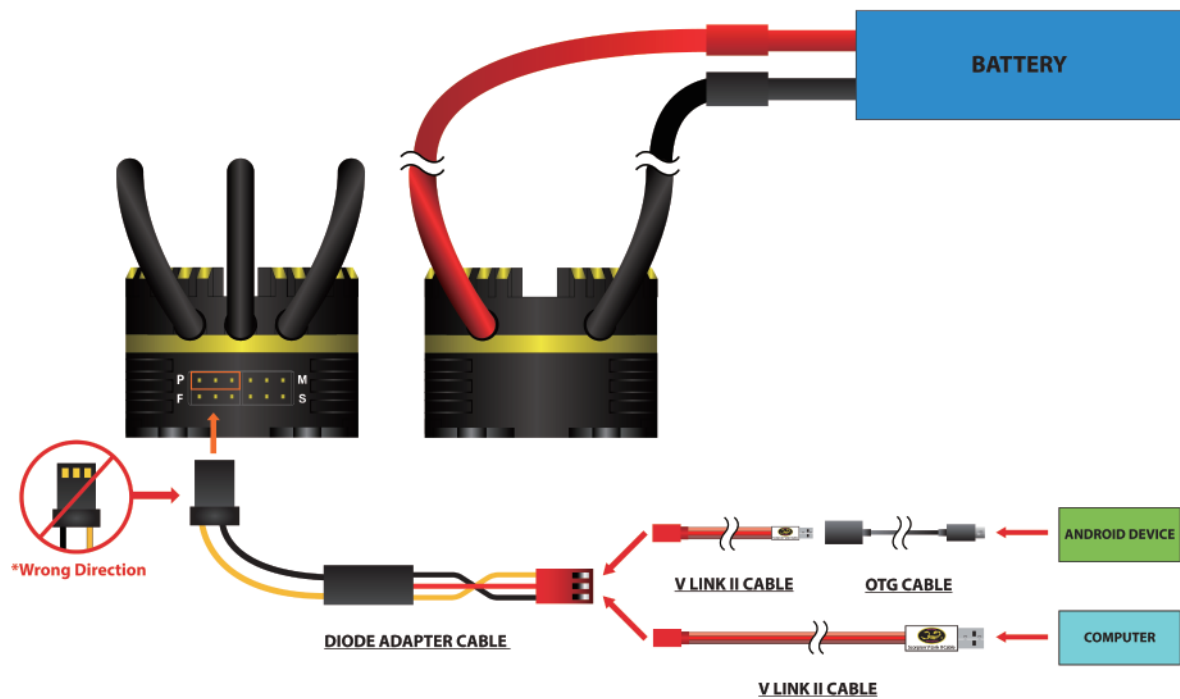

## 5.0 SPROTO Connection

- 5.1 Hook up your ESC using either a USB-C cable or VLink II Cable as shown in Section 4.0
- 5.2 Open the SProto Program, and Launch the Tribunus III Configurator App by double clicking on it, or by single clicking, then clicking on the “Play” button

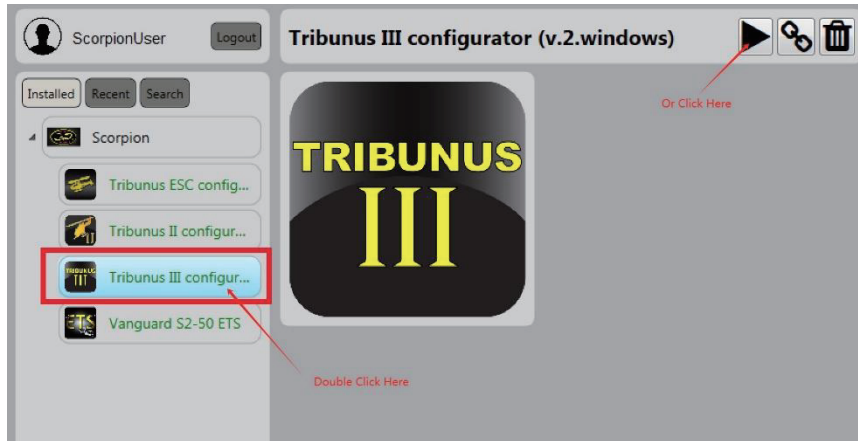

- 5.3 – Check for Successful connection



- 5.4 – If connection does not work the first time, you may try to “Reload” the comport

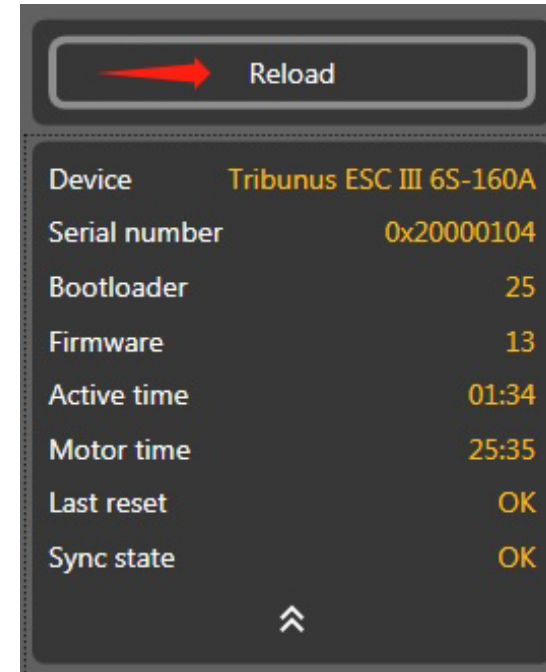

- 5.5 – If you do not have success with connecting the ESC, please check our troubleshooting guide on in **SECTION 17**.

## 6.0 Writing Settings to ESC {IMPORTANT}

**NOTE :** Anytime you change a parameter, the color of the feature will change from grey to green. After making adjustments you must “Upload” the settings to the ESC. Click the “Upload” button and then the ESC will restart, and then your settings will be saved.



## 7.0 Main Settings

Setting	Function	Description
A1	Device Name	User has simple option to "name" the ESC.
A2	Device mode*	Adjust which mode you will be using the ESC in.  <i>(Heli Gov – with re calculated maximum RPM / Heli Gov - with Prestored maximum RPM / VBAR PID / External PID / Airplane /Airplane with Reverse/ Boat)</i>
A3	BEC Voltage	Set your BEC voltage  <i>(5.0 / 6.2 / 7.2 / 8.4 V / 8.8V / 10.0V / 11.0V / 12.1V / OFF)</i>  <b>Note:</b> <i>If setting voltage above 8.4V you must be certain your flight control system and servos, along with all other accessories (fan etc.) can handle the higher voltages! You must check the check box and confirm to “unlock” the higher BEC voltage ranges.</i>
A4	Rotation Direction	Adjust the direction which your motor spins  <i>(CW / CCW)</i>
A5	Communication Protocol**	Adjust which Telemetry Protocol you will be using  <i>(Standard / Vbar / Jeti ex bus / Unsolicited Telemetry / Futaba)</i>
A6	Fan on Temperature***	Adjust at which temperature the cooling fan will turn on

## 7.1 1B - Device Mode\*

Mode	Description
Heli gov - with recalculated Maximum RPM	Scorpion Internal Heli Gov Mode. While spooling up, ESC calculates predicted max RPM based on battery voltage / Motor Selection. This is a "setup" mode useful for checking your gear ratio / rpm to throttle percentage ratios. <i>(RPM Value may change each time you spool up the model)</i> Autorotation Bailout enabled after complete spool up, then switch to 20%-30% throttle. Switch to 0%-10% for normal spool up
Heli gov - with Prestored Maximum RPM	Scorpion Internal Heli Gov Mode. On first spool up, ESC calculates and then locks the max rpm value. In subsequent flights, the RPM will spool to the same value each time relative to same throttle %. <i>The max rpm value can be manually adjusted in Parameter <b>B9 - Governor Maximum RPM</b> See section 8.0 for more info.</i> Autorotation Bailout enabled after complete spool up, then switch to 20%-30% throttle. Switch to 0%-10% for normal spool up
VBAR gov	Mode designed when using VBAR Gov mode. While in this mode, the ESC will have soft start function, but will rely on VBAR governor to control the RPM. <i>(be sure the slave wire is plugged into the RPM port of the Vbar NEO, so that VBAR can properly read the RPM signal)</i>
External gov	Mode designed when using other External Gov Systems (Futaba / Jeti / etc) while in this mode, the ESC will have soft start function, but will rely on the external governor to control the RPM. <i>(be sure the slave wire is plugged into the RPM port of your device, so that device can properly read the RPM signal, <b>be sure to remove vcc/ground from slave wire if using Futaba CGY760!</b>)</i>
Airplane Mode	Airplane Mode provides linear throttle response and fast acceleration
Airplane with Reverse Mode	Airplane with Reverse Mode provides linear throttle response and fast acceleration with option for reversing function on motor direction. See <b>Section 18</b> , for specific calibration process for this mode
Boat Mode	Boat Mode provides linear throttle response and fast acceleration with a shortened initialization time period after plugging in battery power

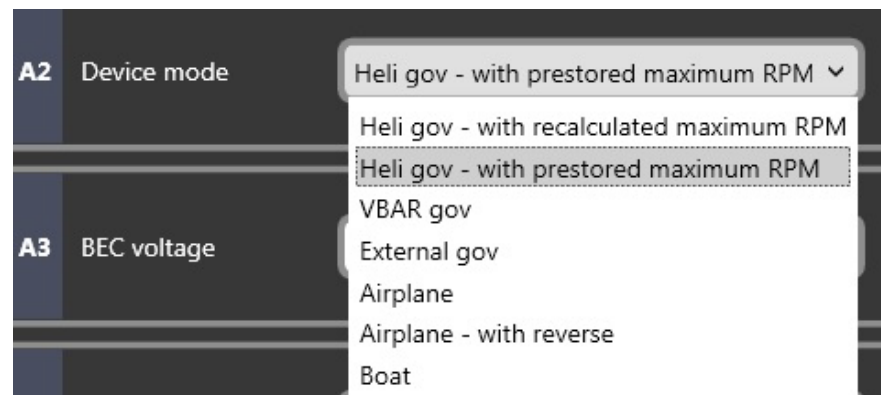

## 7.2 1E - Communication Protocol\*\*

Communication Protocol has to do with the data which comes out of the PC port. Select which protocol you wish to use depending on you receiver / control unit. Cabling goes between the PC port of the ESC to the predetermined data port on your RX or Control Unit. The specific cable which is used is dependent on the system which you use. **See our individual guides for specific telemetry use cases.**

Mode	Description	Required Cable
Standard	No telemetry data is sent when in this mode. Select it if no intention of using telemetry.	N/A
VBAR	2-way communication protocol between Tribunus ESC and Mikado VBAR Control Radio System. This allow the ESC settings to be programmed via the remote control, as well as display all telemetry settings in real time.	Vbar Control / Scorpion ESC Cable
Jeti Ex Bus	Telemetry mode designed to work with Jeti Ex Bus System	"Patch Cable" (male to male servo extension)
Unsolicited*	Unsolicited Telemetry mode. Designed to make telemetry protocol accessible via UART signal, to those who wish to implement it. Such as with an MCU, or ready-made products such as JLOG, Brain FBL, Spektrum (w/ adaptor), etc.	Cabling depends on use case / situation.
Futaba SBUS 2	Telemetry mode designed to work with Futaba SBUS 2. Be sure your Futaba Radio supports Scorpion Telemetry protocol.	"DIY Patch Cable" (male to male servo extension w/ vcc (+) wire removed)

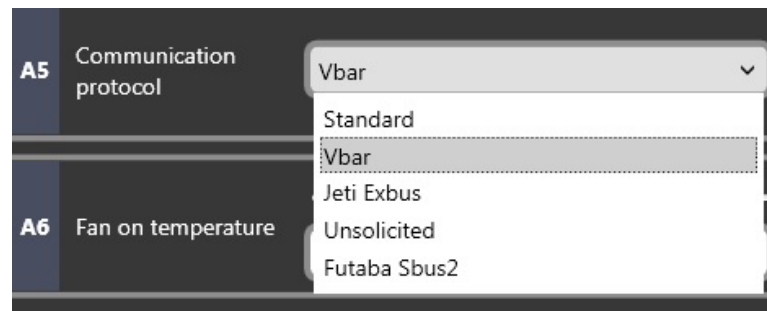

### 7.2.1 Unsolicited Telemetry Mode Overview

- Unsolicited Telemetry mode is our own protocol which is designed to make Telemetry Data accessible over UART signal to those who wish to implement our protocol.
- It can be used by developers who wish to access telemetry data via their own Radio / UAV system.
- It is used with various Telemetry Converter Systems, and also with various existing radio systems which have implemented our protocol for you already.

#### IMPORTANT NOTE FOR PROGRAMING WHEN USING UNSOLICITED TELEMETRY MODE

While in Unsolicited Telemetry mode, you can only connect to the PC software via the VLINK II Cable + Diode Cable for **the first 5 seconds after powering on the ESC**. So, you must "connect" to sproto within 5 seconds of powering on the ESC. After these 5 seconds, the ESC stops looking for USB connections, and starts only sending Telemetry data. If you do not connect within the first 5 seconds, then you will need to power off, and try again.

### 7.2.2 Unsolicited Telemetry Use Cases

Spektrum XBUS Telemetry Protocol	Spektrum Telemetry Specification uses a different protocol then us for their telemetry system. To make Scorpion Telemetry Data accessible on your Spektrum Remote Control, we have created the <b>Scorpion Spektrum X-Bus Telemetry Cable</b> . This cable converts our Unsolicited Telem Protocol into Spektrum Telemetry Protocol. Simply select Unsolicited Telem Mode while setting up your Tribunus ESC, and then connect the Scorpion Spektrum X-Bus Telemetry Cable from the PC port of your ESC to the X.BUS port of your Telemetry enabled Spektrum RX and then follow Spektrum Telemetry instructions to setup your radio.
Telemetry Converter Systems	Some 3 <sup>rd</sup> party companies have implemented our Telemetry protocol into their own products, which can convert the telemetry to various other protocols and system. Such as JLOG, RCLightSystems, etc.
Telemetry to Microcontroller	Our Telemetry protocol can be implemented easily into your own radio / UAV system with any number of microcontrollers
Other Radio / FBL Systems	Some radio / FBL system has already implemented our protocol into their system which allows you to connect directly. Be sure to check with your radio / fbl manufacture to see if they support Scorpion Unsolicited Telem.

**For more information about our Unsolicited Telemetry Protocol please email us at [support@spihk.com](mailto:support@spihk.com)**

## 8.0 Heli Settings

Helicopter settings are only adjustable when using Scorpion's Internal Helicopter Gov with Prestored / Recalculated values and external gov mode.

If in Vbar Mode, or airplane / other mode, you will not have access to the Heli Parameters.

You can either click the default presets, Soft/ Medium / Fast (Hard), or you may type in a specific value which you prefer.

Autorotation Bailout enabled after complete spool up, then switch to 20%-30% throttle. Switch to 0%-10% for normal spool up.

Be sure to save the settings to your ESC after adjustment.

**Note:** Tribunus has dynamic timing and frequency, so there is not user adjustable **Timing or Frequency** adjustment. The ESC sets it automatically and dynamically depending on the motor load and rpm.



Parameter	Name	Default Value	Description
B1	Soft Start speed	10,000ms	Adjusts the acceleration speed of the soft start for first 0%-30% of power level
B2	Acceleration speed	8,000ms	Adjusts the acceleration speed of the soft start between 30% - set throttle % of your throttle curve. This value also effects the speed of rpm change when switching between different throttle % values.
B3	Bailout Acceleration speed	2,000ms	Adjust the speed of the autorotation bailout function Autorotation Bailout enabled after complete spool up, then switch to 20%-30% throttle. Switch to 0%-10% for normal spool up
B4	Governor Preset Type	Medium	Adjust the Governor Sensitivity Presets (Soft / Medium / Hard / Custom)
B5	P gain	1.0	Adjusts the initial response of the headspeed governor. To High Value = Overspeed on initial collective/ cyclic pitch movements To Low Value = RPM Drop on initial collective / cyclic pitch movement
B6	I gain	2.0	Adjust the holding power of the headspeed governor. To High Value = Overspeed on sustained collective / cyclic pitch movements To Low Value = RPM Drop on sustained collective / cyclic pitch movements*  <i>(RPM drop in this situation could also be a result of bad gearing / not powerful enough motor / battery)</i>
B7	D gain	0.45	Non - Adjustable
B8	I gain Correction	Enabled	This function is designed to help smoothen the torque changes from governor response. Overly aggressive governor response may cause your tail rotor to kick out under rapid pitch / torque changes. Enabled – Use this mode when doing 3d flying Disabled – Use this mode when you require maximum power regardless of the governor effect on other aspects of flight (example speed flying)
B9	Governor Maximum RPM	0 / max rpm	Calculated Maximum governable rpm of the system. The displayed value depends on which settings you have set in Pole Pairs (5B), and Gear Ratio (5A). If you have Gear ratio / Pole Pairs set to 1 (default) it will show electrical rpms of the motor (Pole Pairs * RPM). If you have pole pairs set, it will show Motor RPM If you have pole pairs, and gear ratio set, it will show main rotor RPM If using "Heli Gov – with recalculated maximum RPM", this value will reset to zero after each power off. Once you run the motor, then the calculated maximum RPM of the model will be set here. Each time you spool up the model, you would have a slightly different RPM depending on the initial voltage of the battery. If using "Heli Gov - with prestored maximum RPM", this value will set itself to the calculated maximum RPM of the model on first spool up. RPM will be the same value relative to your throttle % value each flight. Note: Some motor designs will cause the Tribunus to calculate a wrongly predicted max RPM value. In this case, if the user wants to override the Tribunus calculation, you may enter your desired max RPM manually.

## 9.0 Airplane / Airplane with Reverse / Boat Settings

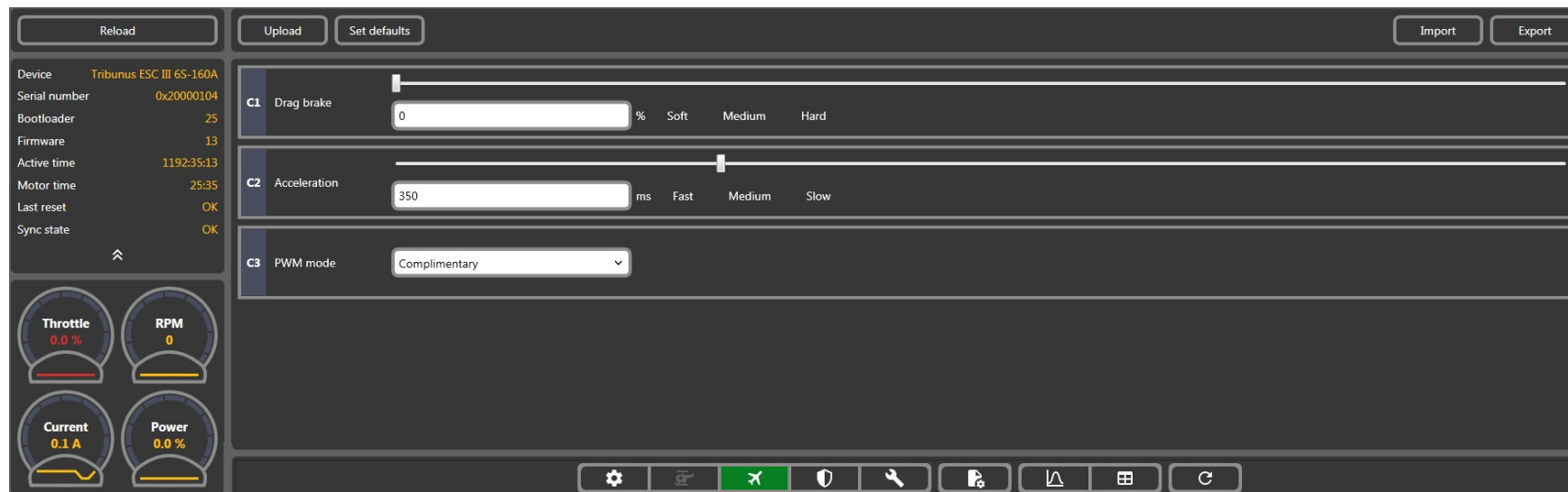

The Tab for this page will change depending on the **Device Mode** which you have selected in Adjustment **A2**. If Airplane mode is selected, then "Plane" tab will appear, same respectively for Airplane with Reverse Mode, and Boat Mode. All 3 mode have the same parameters. You can either click the default presets, Soft/ Medium / Fast, or you may type in a specific value which you prefer.

Be sure to **SAVE** the settings to your ESC after adjustment.

Parameter	Name	Default Value	Description
C1	Drag Brake	0%	<p>Sets the intensity of the "brake" function of the ESC when throttle signal is set to 0%.</p> <p>Note : In complimentary mode, there will be always a braking effect in flight due to the regenerative freewheeling effect even if you set 0% brake force.</p>
C2	Motor Acceleration	350ms	<p>Sets the acceleration speed of the motor.</p> <p>NOTE : Depending on the size / weight of your prop, setting a too low Motor Acceleration value (too fast acceleration) may cause exponentially high phase current values which can damage you ESC and <b>VOID YOUR WARRANTY</b>.</p> <p><b>Please follow the recommended Motor Acceleration ranges depending on your Propeller size.</b></p> <p>100ms-250ms: not recommended                      250ms-350ms: 18" prop size and smaller                      350ms - 500ms: 18" - 24" prop size                      500ms + : 24" prop size and larger</p>
C3	PWM Mode	Complimentary	<p>PWM Mode manages different ways in which the esc handles generated current on RPM deceleration.</p> <p><b>Complimentary</b> (recommend) - This is a partial Freewheeling Mode. On RPM deceleration, generate voltage is directed back into the battery. This mode has a mild brake effect on RPM deceleration</p> <p><b>Regular</b> - This mode dissipates generated voltage through resistors. It is only recommended when using a power supply rather than a battery to power the ESC.</p> <p><b>NOTE: It is dangerous to power your ESC with a Power Supply! If you do this, you must take additional precautions! See note in section 16.0</b></p>

**Note:** Tribunus has dynamic **Timing and Frequency**, so there is not user adjustable Timing or Frequency adjustment. The ESC sets it automatically and dynamically depending on the motor load and RPM.

# 10.0 Protection Settings

Scorpion protection features follow the following procedure. If a value surpasses a protection limit, then the ESC will slowly start to limit the power output of the ESC down to the Power % which is set by D5 – Cut off Power Level, over a period of time which is set by D1 – Cut off Delay. If during this time period the value comes below the protection limit, then the power will be restored. If the value does not come below the protection limit, then the ESC will continue to limit power down to the Power % which is set by D5 – Cut off Power Level. If at any time after this, value goes below the protection limit, then power will be restored.

**Cut off Limit is not a fixed value %. It is a multiplication to requested power. So if cut off limit is set to 70%, but you are flying only at 50% throttle, then you will still be aware of the protection limit because your 50% requested power would actually be (50% \* 0.70 = ) 35%.**



Parameter	Name	Default Value	Description
D1	Cut off delay	5000ms	When a value goes over the protection limit, the ESC will slowly start to reduce the power output % to the cut off limit. This value adjusts how long this power reduction period takes. (Unit is milliseconds. 5000ms = 5 seconds)
D2	Minimum voltage	8.0V	Protects against over discharging your battery. Sets the minimum total battery voltage allowed before the ESC engages the protections. <b>NOTE :</b> When setting this value, be sure to take into account that during flight your battery voltage will sag under load. We recommend to not set a minimum voltage protection higher than (3.0V * # of cells)
D3	Maximum temperature	85C	Protects the ESC from over temperature. <b>NOTE:</b> While the components are rated for temperatures above 100C, consistent use at high temperature increases the rate of degradation. Be sure to use one of our hi-speed cooling fans, or change ESC location to get better natural airflow if your ESC is near the Temperature limit consistently.
D4	Maximum Current	(depends on ESC size)	Limits the maximum battery current of the ESC <b>*See detailed explanation on next page*</b>
D5	Cutoff Power Level	70%	When a protection is engaged, the power is slowly reduced. This value adjusts to which limit the power can be reduced to. Cut off limit is not a fixed % value. It is a multiplication of requested power.
D6	Battery Capacity Cutoff	0.00Ah	Optional protection to signal to user when his battery is discharged. Set the value of Amps (Ah*1000 = mah) you wish to use. When you reach that limit, then the ESC will reduce the power signifying to you it is time to land. <b>NOTE:</b> If you do not wish to use this function, set 0.00 and it will disable the function.

## 11.1 Maximum Current Protection Algorithm

For Tribunus III series we have implemented a new protection algorithm for Maximum Current. To understand the purpose of this you must first understand the important difference between Battery Current (A), and Phase Current (A). When an ESC drives a motor, the MOSFETS turn ON and OFF power to the different phases of the motor in a specific sequence to rotate the motor. At 100% power, this means that the MOSFET is passing 100% of the battery voltage to the phases of the motor. For the sake of this example we can say, if you are running 50% power, then this means that the MOSFET is only passing 50% of battery voltage to the phases of the motor.

Since we know Watts = Voltage \* Amps, or in other words Amps = Watts / Voltage then we can calculate the following examples.

**Ex. 1** – If your airplane / helicopter is properly set up, with a correct sized propeller / gear ratio. With a 6s Battery (22.2V), you run 100% throttle, and your motor is pulling 100A under load, then we can calculate the following.

**Battery Current** -  $100A \times 22.2V$  (battery voltage) = 2,220 Watts

**Phase Current** -  $100A \times 22.2V$  (MOSFET voltage) = 2,220 Watts

**Ex 2** – If your airplane / helicopter is improperly setup, with too large of propeller / wrong gear ratio. With 6s Battery (22.2V), you run only 50% throttle, and you're still pulling 100A under load. Keep in mind, since we are at 50% throttle, this means the MOSFETS are only sending 50% of the voltage to the motor phases. Then we can calculate the following.

**Battery Current** -  $2,200 \text{ Watts} / 22.2V = 100A$

**Phase Current** -  $2,200 \text{ Watts} / 11.1V$  (MOSFET voltage at 50%) = 200A

As you can see, even though the battery current is the same, the phase current is much higher. When running partial throttle percentages, the phase currents can rise exponentially. Higher phase currents cause more efficiency losses, and higher temperatures not to mention can quickly and easily fail due to excessive load. This is why there is such importance on proper gear ratio / propeller setup.

To combat users who run our ESC product with improper propeller selection / gear ratios we have implemented the following Maximum Current Protections.

### - **Maximum Current Protection now additionally regulates calculated PHASE CURRENT, and not only BATTERY CURRENT**

The noticeable effect of this, is that now in terms of battery current, your "maximum current" value can only be achieved when running at 100% throttle. If you are running partial throttle %, with very high load, you may notice that your "battery current" may begin to be regulated far before your "maximum current" value is reached. This is because due to your partial throttle %, the phase current is already exceeding the Current Limit, and therefore the ESC is regulating the power output.

Another effect (in extreme cases) could be you may note slower acceleration. If your acceleration is set to fast / your propeller is very heavy, the phase current to spool up the propeller may exceed the phase current limit, which would enable the protection and effectively "slow down" your throttle acceleration to a rate which does not cause the phase currents to exceed the set limit.

If you notice your power is excessively regulated due to this fact, be sure to check your gear ratio / propeller / power system setup to make sure that it is operating within a healthy and reasonable manner.

NOTE: Over Current protection are a feature to protect against immediate failure, however, constantly putting the ESC above its continuous current rating and pushing it often to, and past, the peak current rating (causing the ESC to activate the protections) places additional stress on the ESC, and may lead to premature component degradation and possibly even failure. Be sure your ESC is appropriately sized for your intended application.

If you see in your log "CURR" warning constantly, then it means the over current protections are being activated, and your ESC is on the limit of its capability and your model setup should be adjusted.

# 11.0 Configuration Settings

Configuration settings **DO NOT EFFECT** how the ESC drives the motor. They are only calibrations, personal settings, and some other settings. There is no configuration adjustment in the ESC which can make the ESC drive the motor improperly.

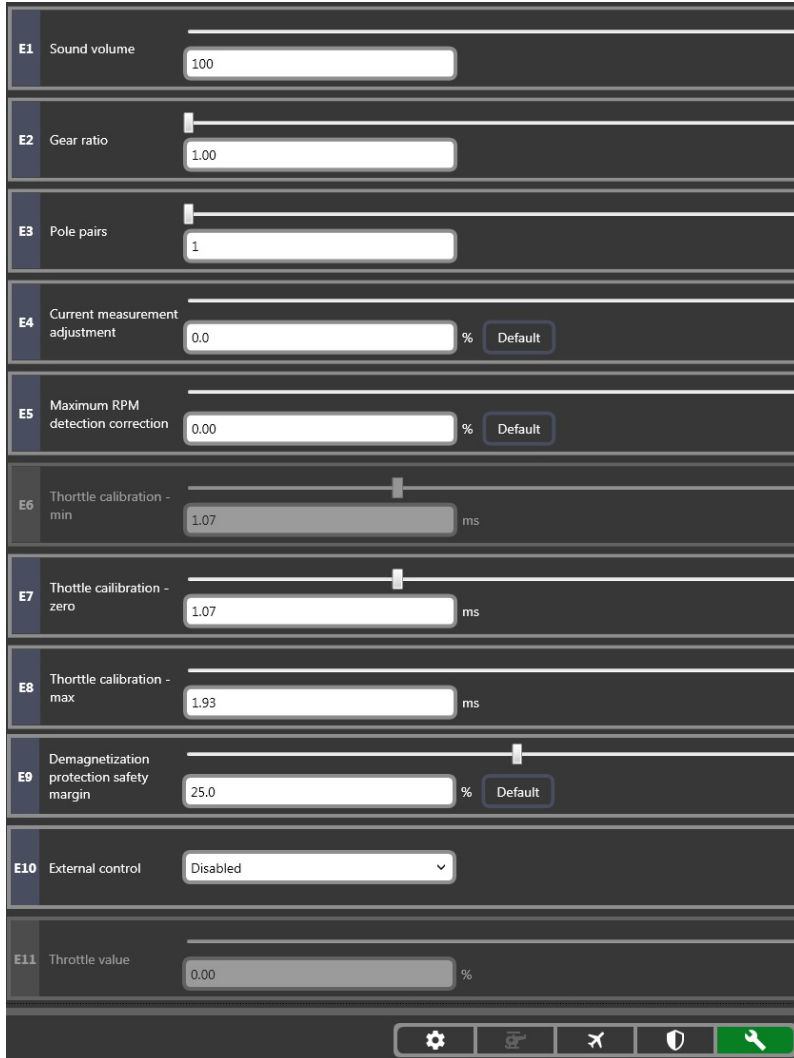

Parameter	Name	Default Value	Description
E1	Sound Volume	100	Set the volume of the POS and error codes 0 = off / 100 = full volume
E2	Gear Ratio	1.00	Set the Gear Ratio used in your power system. <i>NOTE: This does not affect how the ESC drive the motor. This only effect how the RPM is displayed in the Log.</i>
E3	Pole Pairs	1	Set the # of pole pairs your motor has. Ex. If you have a 10 pole motor, then you should set 5 pole pairs <i>NOTE: This does not affect how the ESC drive the motor. This only effect how the RPM is displayed in the Log.</i>
E4	Current Measurement Adjustment	0%	Tribunus ESC's can measure the Current (Amps) your ESC pulls. This data is used for the telemetry and to calculate the MAH used during flight. <b>However, during production there may be tolerance in this measurement, and each ESC may measure slightly different.</b> Adjust this value to compensate for tolerance on the displayed current measuring.
E5	Maximum RPM Detection Correction	0%	In the Recalculated Gov mode (and on the first spool up of Prestored Gov mode), the ESC auto calculates maximum RPM. If this calculation is wrong, you can adjust the % change to calculated Maximum RPM of the governor.
E6	Throttle Calibration MIN	1.07ms	If using the "Airplane Mode with Reverse" mode, this value adjusts the throttle signal value for -100% "reverse" throttle. <i>If user does the "throttle calibration" via the stick programing, this value will automatically set itself. However, user may choose to manually set it.</i>
E7	Throttle Calibration Zero	1.07ms	This Value adjusts what the ESC perceives is "off" throttle position. Different transmitter brand may have different values for this point. If the Transmitter point is higher than the ESC point, then the ESC will not arm. <i>If user does the "throttle calibration" via the stick programing, this value will automatically set itself. However, user may choose to manually set it.</i>
E8	Throttle Calibration MAX	1.93ms	This value adjusts what the ESC perceives is "max throttle" position. Different transmitter brand may have different values for this point. If the Transmitter point is lower than the ESC point, then it will not go to 100% throttle. <i>If user does the "throttle calibration" via the stick programing, this value will automatically set itself. However, user may choose to manually set it.</i>
E9	Demagnetization Protection Safety Margin	25%	Some motors have demagnetization problems which prohibit the ESC from driving them past a certain Current amount. Tribunus ESC have a protection against this which reduce power if the motor is in this state. This value adjusts the Safety margin of the demagnetization protection.  <b>NOTE: Unless specifically needed, leave this value at 25%!</b>
E10	External Control	Disabled	Optional setting to enable or disable the ability to turn on the motor from the SPROTO app using the below value E11 to adjust the throttle %
E11	Throttle Value	0%	If the above value E10 is set to enabled, you can use this adjustment to run the motor via the sproto app.

## 12.0 Firmware

**\*\*\*You must be logged into your SPROTO account to be able to view / update the ESC firmware\*\*\***

It is very important to keep your **Tribunus ESC up to date!** As time goes on, we may improve the drive algorithm, protections, function, or fix bugs in the ESC firmware. Also, as other Transmitter update their software's, we may need to adjust our Firmware to adjust to their updated telemetry protocols.

**NOTE:** When you update the firmware, it will over write your existing setup parameters. This is a safety function to ensure no value gets set erroneously during the update process.

You should **SAVE** your settings **PRIOR** to doing the Firmware update if you wish to keep your previous settings.  
Learn how to save your settings in Section 15 of this manual.

The screenshot displays the SPROTO interface for a **Tribunus ESC III 6S-160A**. The left sidebar contains the following information:

- Device: **Tribunus ESC III 6S-160A**
- Serial number: **0x20000104**
- Bootloader: **25**
- Firmware: **13**
- Active time: **23:29**
- Motor time: **25:35**
- Last reset: **OK**
- Sync state: **OK**

The main area shows the current firmware version: **6S-160, version 13**, with a timestamp of **30.10.2023 20:23** and a **Reinstall** button. A red arrow points to the **Reinstall** button.

The bottom navigation bar includes icons for settings, flight, airplane, shield, wrench, and a green **Refresh** button.

# 13.0 Logs

Tribunus ESCs have a very good data logging function. Data is logged every ~0.2 seconds while running, and every ~1.1 second while idle. This data can be accessed in real time using our telemetry functions, but it can also be downloaded / viewed / saved / exported, using our SPROTO program.

The log data is stored on the ESC. When the memory is full it simply begins over writing previous data which was stored. The log can record several flights worth of data.

**NOTE: In default setting, the RPM which is shown is the electrical RPM of the ESC. If you wish to show the actual prop / disc rpm, then make sure in your configuration tab you enter the proper pole pairs / gear ratio values prior to Loading the log data.**

## 13.1 How to access logs

Step 1: Connect your ESC to Sproto Program

Step 2: Click into the **Log Chart** tab



Step 3: Update the Log

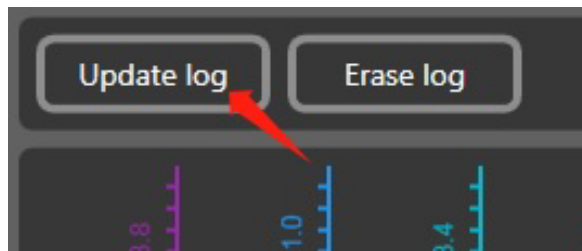

Step 4: Wait for the log to upload to Sproto from the ESC

(may take some time depending on how full the log is)

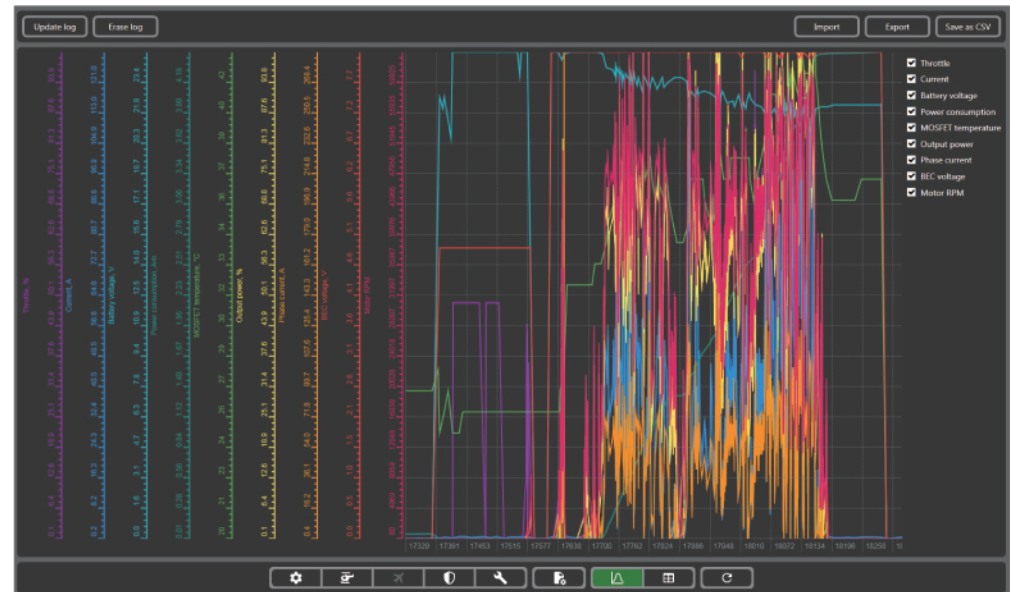
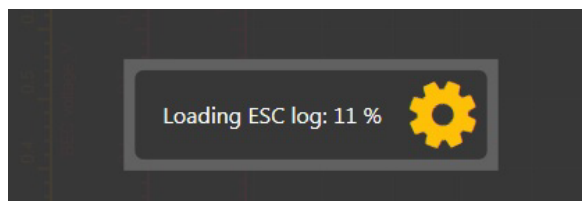

Update Log	Due to the amount of log data stored in the ESC, the log is not automatically downloaded when you connect the ESC. If you wish to view the log data, then while the ESC is connected to Sproto, you must click here, and Download the log data from the ESC.
Erase Log	Delete the log data from the ESC (not required to do so)
IMPORT	If you wish to view a previously exported log, you can use the "IMPORT" function to load in a previous exported log (.tgb format) for viewing / comparison purposes.  NOTE: ESC does not need to be connected for this.
EXPORT	If you wish to save, or send the log data, then you can do so with the EXPORT function. Click here, and then save the data to your PC in the .tgb file format.
Save as CSV	If you wish to use the data outside of our Sproto program, then you may use this function to export the log data to .CSV format.

## 14.0 Filtering the Log Data

You can check / uncheck the checkmark next to the data to choose to view or not view the data in the log chart. This feature allows you to filter the data and view only the information which you wish.

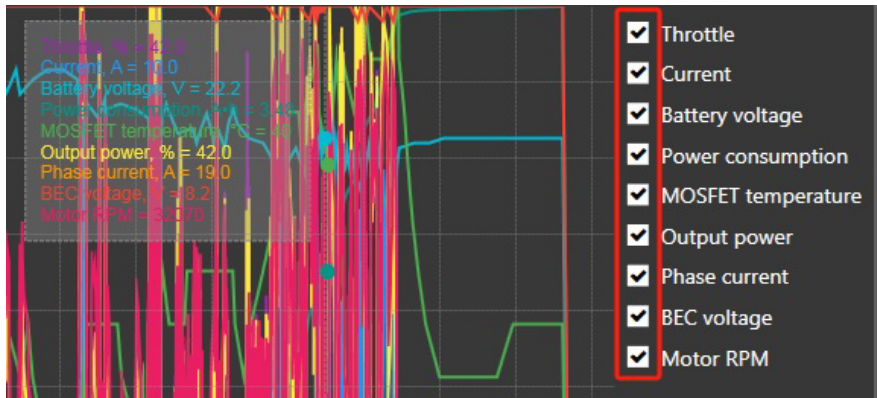

## 14.1 Navigate the Log Data

To zoom in on a section of the log, you can simply click and drag from the top left, to the bottom right of the section which you want to view. This will zoom the log to the section you wish to view.

You can then use the right mouse click, to move the view around the log, and the mouse scroll wheel to zoom in and out.

To zoom out, you can also drag from the bottom right to the top left.

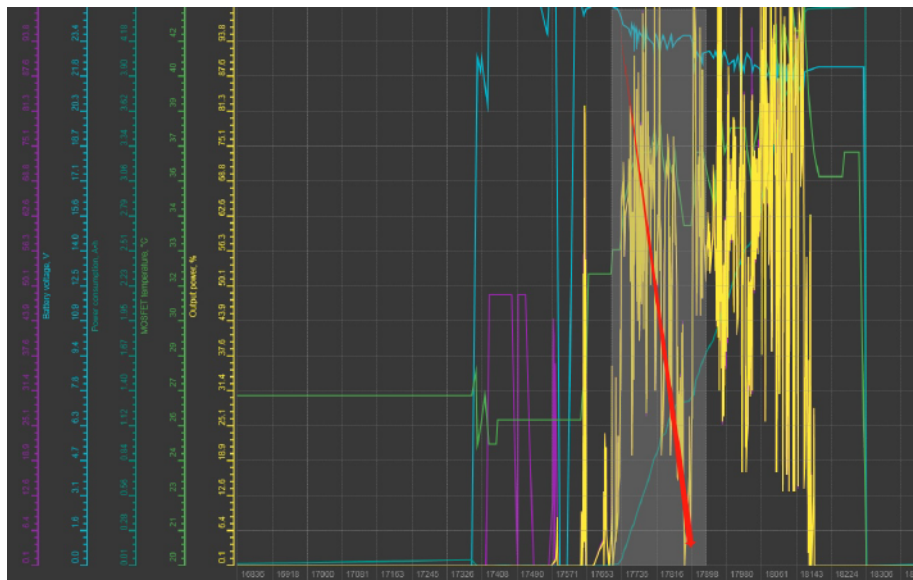

## 14.2 Viewing the data in Table Format

You have the option to view the log data in Table format vs Chart format. This option lets you see more clearly the exact measured values at each specific time stamp. Additionally, in this Table Format, you can see Error codes which are flagged by the ESC.



Note: The "time" stamp of the log data in the chart, and table format correlate. So, if you note the time stamps of an event in the chart log, then you can find the exact moment in the table format using the time stamp.

Time, s	Throttle, %	Current, A	Battery voltage, V	Power consumption, A·h	MOSFET temperature, °C	Output power, %	Phase current, A	BEC voltage, V	Motor RPM	Errors
18969.0	36.0	5.9	23.2	0.048	24	43.0	9.1	4.9	25285	--
18969.2	36.0	6.0	23.2	0.048	24	43.0	9.3	4.9	25290	--
18969.5	36.0	5.9	23.2	0.048	24	43.0	9.1	4.9	25315	--
18969.7	37.5	6.0	23.2	0.048	24	43.5	9.2	4.9	25430	--
18969.9	41.5	6.8	23.1	0.048	24	46.5	10.3	4.9	27185	--
18970.1	41.5	7.4	23.1	0.049	24	49.5	10.9	4.9	28905	--
18970.3	41.5	7.6	23.1	0.049	24	49.5	11.3	4.9	29095	--
18970.6	41.5	7.7	23.1	0.050	24	50.0	11.4	4.9	29085	--
18970.8	43.5	8.2	23.1	0.050	24	51.0	12.2	4.9	29585	--
18971.0	47.0	8.9	23.1	0.050	24	54.5	12.7	4.9	31490	--
18971.2	47.0	9.8	23.0	0.052	24	57.0	13.7	4.9	32755	--
18971.4	49.0	10.3	23.0	0.052	25	58.5	14.2	4.9	33605	--
18971.6	52.5	11.1	23.0	0.053	25	62.0	14.7	4.9	35475	--
18971.9	54.5	12.3	23.0	0.053	25	65.5	15.7	4.9	37380	--
18972.1	58.5	13.8	22.9	0.053	25	69.0	17.1	4.9	39240	--
18972.5	60.0	15.1	22.9	0.055	25	72.5	18.1	4.9	40790	--
18972.7	62.0	15.9	22.9	0.057	25	75.0	18.5	4.9	42135	--
18973.0	66.0	17.4	22.8	0.057	25	78.5	19.6	4.9	44070	--
18973.2	67.5	18.8	22.8	0.060	25	82.0	20.5	4.9	45965	--
18973.4	69.5	20.5	22.7	0.060	25	86.0	21.5	4.9	47730	--
18973.6	69.5	21.2	22.7	0.060	25	86.5	22.2	4.9	48195	--
18973.8	69.5	21.5	22.7	0.063	25	86.5	22.5	4.9	48265	--
18974.0	71.5	22.1	22.7	0.063	25	88.0	22.8	4.9	48955	--
18974.3	73.0	23.5	22.6	0.066	25	91.0	23.6	4.9	50720	--
18974.5	74.0	24.2	22.6	0.066	25	92.0	24.1	4.9	50910	--
18974.7	73.0	24.4	22.6	0.066	25	91.5	24.5	4.9	50935	--
18974.9	73.5	24.3	22.6	0.069	25	92.0	24.2	4.9	50935	--
18975.1	73.0	24.5	22.6	0.069	25	92.0	24.5	4.9	51075	--
18975.4	73.0	24.4	22.6	0.073	25	91.5	24.5	4.9	50760	--
18975.6	70.0	24.1	22.6	0.073	25	90.5	24.4	4.9	50255	--
18975.8	60.5	22.6	22.6	0.073	25	87.0	23.7	4.9	48435	--
18976.0	59.5	20.8	22.6	0.076	25	83.5	22.5	4.9	46615	--
18976.2	60.0	19.3	22.7	0.076	25	79.5	21.8	4.9	44885	--
18976.5	61.0	17.5	22.7	0.078	25	76.0	20.4	4.9	42895	--
18976.7	67.5	17.8	22.7	0.078	25	79.0	20.0	4.9	44240	--

Note: You can also easily highlight columns of log data in the "Table" Form and use these to paste into external programs such as Excel / Google Sheets, etc.

# 15.0 Setting Files

Users can save current ESC settings into the SPROTO program, and re load them into other ESC / send the setup file if needed.

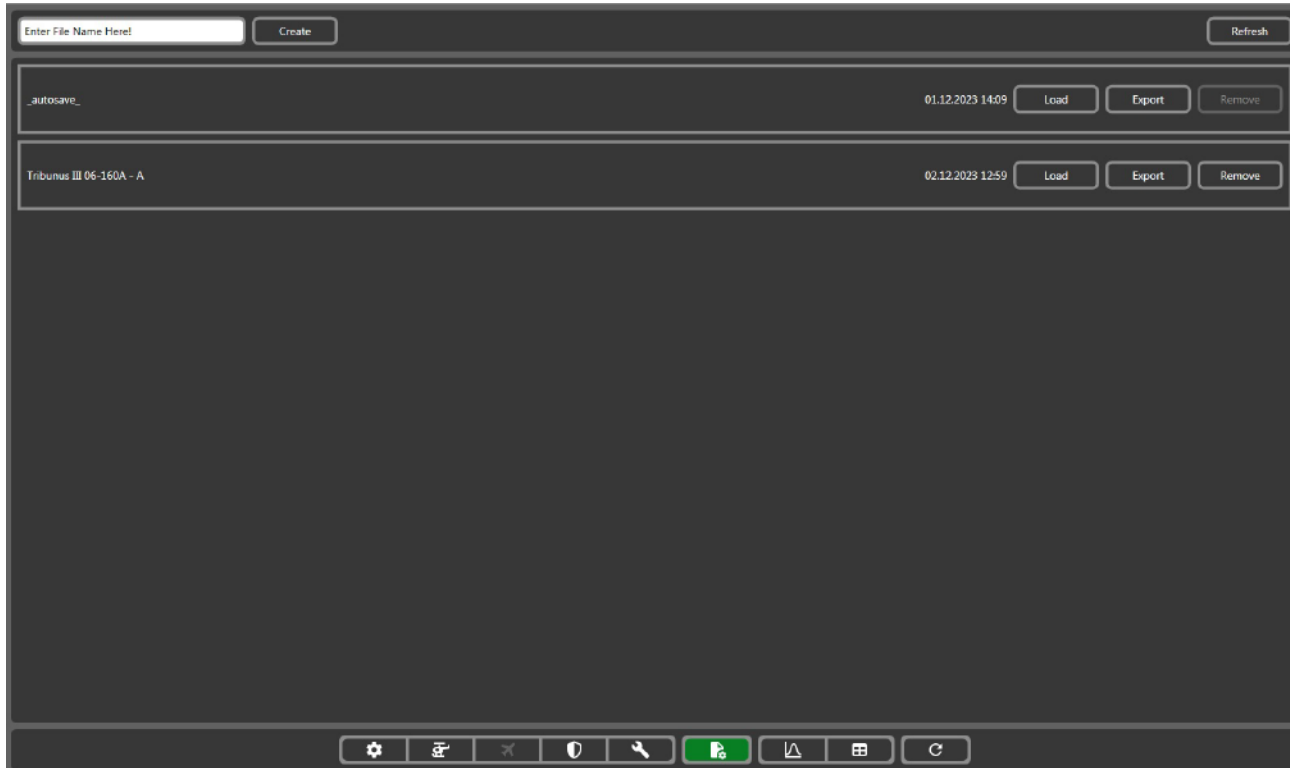

## 15.1 Import Settings directly from PC to ESC

To directly import a previously saved .json file to your ESC. Click into any of the settings tabs, and look for the "IMPORT" button. Then select the .json file and load it.

Note: Loading the .json file only populates the settings in the sproto program. After checking settings, you must click "upload" to send them to the ESC.

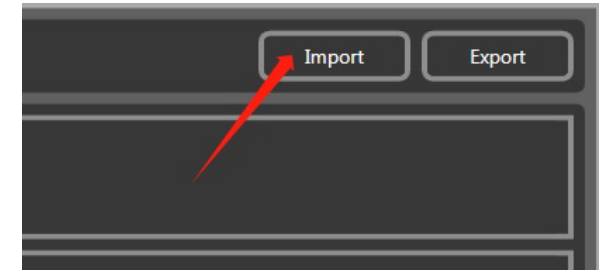

## 15.2 Export Settings directly from ESC to PC

To directly export your setting file to the PC. Click into any of the settings tabs, and look for the "EXPORT" button. Then set a file name, and save the .json file to you PC.

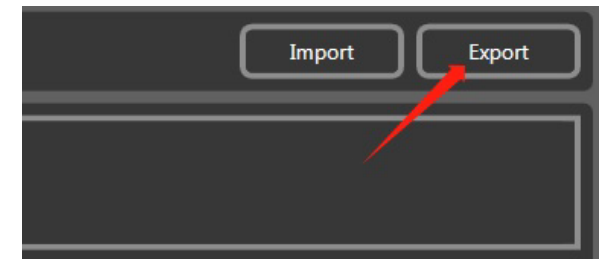

Create	Enter a file name, and click Create to save the current ESC settings onto the SPROTO APP which can be viewed in the list of "Saved Settings"
LOAD	Load the setup file parameters into the Sproto program. <i>NOTE: Loading the parameters, only changes the value in Sproto, but does NOT send them to the ESC. If you wish to send these changes values to the ESC, you must click to one of the other setup tabs, inspect the values, then click "Upload" to send the settings to the ESC.</i>
EXPORT	Save the setting file onto your PC (.json file)
REMOVE	Remove a Saved Setting, from the list shown in Saved Setting tab of Sproto.

## 16.0 Instructional Guide for using Tribunus ESC's with Power Supply or Long Power input cable in flight or for bench testing / endurance testing

Scorpion Tribunus ESC's are designed for use in Flight Applications. This implies that in the stock configuration, the Tribunus ESC's are designed to work only with a form of battery as power input, and reasonably short length of battery wires.

Tribunus ESC's are **NOT** designed to be used with POWER SUPPLIES, or exceptionally LONG POWER INPUT cables, without additional precautions. Using the Tribunus ESC's in these situations, without the additional required precautions may damage your ESC and will VOID THE WARRANTY. See specific details below.

### Using the Tribunus ESC's with Power Supply for bench testing –

Using a power supply to power an ESC while spinning a motor is an exceptionally bad idea unless proper precautions are taken. In many situations, BLDC motors act as generators which can create current which gets fed back to the ESC. In a normal situation with a battery, this generated current gets absorbed by the battery. However, most power supplies (even high-quality ones) do not have the same capability to absorb, or dissipate this generated current. The result is that the power supply can generate a very high, instantaneous, voltage spike. If the voltage spike is above the capability of the ESC components, then it will directly damage your ESC.

If you are required to power your Tribunus ESC with a power supply, then you must take the necessary precautions or else you will VOID your warranty!

In order to stabilize the voltage and protect the ESC from damage when used in this situation, you must have a way to absorb generated current. This can be either a very large, high voltage, and high capacitance capacitor, or even a lipo battery which is connected in line to the power supply (ensure power supply voltage, is not higher than the battery voltage). In the case of capacitors, the amount of capacitance required, depends on your exact use case, so please take this into your calculations prior to testing using a power supply. If you are unsure and unable to calculate this, then we recommend only that you simply use a battery to power your ESC.

### Using the Tribunus ESC's on a test stand or even in flight with very long power input cables –

Over long length of wires, Voltage will fluctuate / sag. If you are using longer than stock length power input cables from your battery to the ESC (in the case of a bench test stand where the motor / ESC is far away from the battery, or even in large aircraft where the battery is located far away from the ESC), and pulling high current loads, then this can cause the voltage to sag and become unstable. This unstable voltage is very hard on the ESC components and likely will lead to ESC failure.

If you are required to power your Tribunus ESC with very long power input cables, then you must take the necessary precaution or else you will VOID your warranty!

In order to stabilize the voltage and protect the ESC from damage when used in this situation, you will need to add additional capacitors before the ESC. We recommend to solder 1 x Scorpion 80V 1880uF Capacitor board for each 1M length of wire. Doing this will provide stable voltage along the length of the wire and protect your ESC from damage.

### Scorpion 80V 1880uF Capacitor board

[https://www.scorpionsystem.com/catalog/speed\\_controllers/accessories\\_2/cap\\_boards\\_filters/80V\\_188uf\\_cap\\_mount/](https://www.scorpionsystem.com/catalog/speed_controllers/accessories_2/cap_boards_filters/80V_188uf_cap_mount/)

If you have additional questions about this topic, and require more information, then please do not hesitate to contact us at

[support@spihk.com](mailto:support@spihk.com)



# 17.0 Troubleshooting Tips

## 1. ESC will not connect to SPROTO

- Make sure you PC is connected to the internet so that the drivers may automatically download from the internet. This may take some time, so be sure to wait sufficient time and check the driver install status.
- If the drivers do not download automatically, be sure you have the proper driver downloaded and saved into the proper file location. Check **Section 4.1** for more details on the best way to download your drivers.
- If using USB cable to connect, be sure that it is a **“Data”** cable and not only a **“charging”** cable. If it is a charging only cable then it will not work.
- If using a laptop or PC which is Bluetooth enabled, please disable Bluetooth function while trying to connect the ESC to Sproto. Sometimes the PC can try to connect via a Bluetooth comport, rather than the USB comport.
- Be sure you are using the Tribunus III Configurator, and not the Tribunus I or II Configurator. Check **Section 6.0** for more details.
- Make sure your USB cable is not worn out with intermittent connection.
- **Try power cycling your PC.**
- If using the Vlink II cable, then be sure that you are also using the “diode cable” between the Vlink II cable, and the ESC. A normal male to male servo extension will **NOT** work, and may damage your ESC and/or PC USB ports.
- If using Vlink II cable, be sure you are applying battery power when trying to connect to the PC.
- If using the Vlink II cable, make sure all connections are made correctly! Check the connection orientation of the vlink II cable into the diode adaptor, and also check to make sure your cable is plugged correctly into the PC port of your ESC.
- If you have previously selected **Unsolicited telemetry mode**, then please note the following important point. The ESC will only be looking for USB connection for the first 5 seconds of powering on. After these seconds, it will switch to sending telemetry data, and will no longer connect to the USB port of your PC. Therefore, connection to the SPROTO program, must happen within the first 3-5 seconds of powering on your ESC!

## 2. I created an account on SPROTO, but did not receive the confirmation code by email

- Be sure to check your junk / spam folder.
- Some email servers, block the emails from our server. There is nothing we can do about this. If the confirmation code continually does not arrive, then please email us at [support@spihk.com](mailto:support@spihk.com) and we can help you log in.
- Try to use a different email address from a different email provider.

## 3. When I try to register and account on Sproto, there is no “Register” button and I can not create or log into my account

- Some PC have issue with the operating language which is set on your PC.
- Change your operating language setting of your PC to English, and attempt again.

## 4. When using Vbar Gov, my RPM does not change and is only at a fixed value

- The RPM signal is passed through the signal wire of the salve BEC cable.
- Be sure to plug the Slave cable into the RPM port, of your VBAR NEO.
- Do NOT plug into the “sensor port”.

## 5. My Throttle Calibration does not work

- Some radio systems (specifically Spektrum), first output a “failsafe signal” prior to binding, which may interfere with the calibration process and require additional steps. Check **Section 2.3** for more information.
- Be sure to check that your cabling is proper, and that the MASTER BEC cable, is going to your throttle port of your RX.
- Be sure that your throttle direction is set correctly so low throttle is ~1000 us, and high throttle is ~2000us. Specifically, with Futaba, you may need to reverse your throttle channel direction.
- Be sure you do not have a throttle hold enabled when trying to do the calibration.

## 6. My ESC keeps beeping after the power on sound

- Be sure to have done the throttle calibration as explained in **Section 2.3**.
- Double check your connections to make sure the MASTER BEC cable is plugging into the Throttle Channel Port of your RX.

## 7. My motor won't spin even if I raise the throttle %

- The ESC won't allow the motor to spin unless it first sees 0% throttle during initialization. Be sure your throttle is correctly calibrated as explained in Section 2.3.
- In heli mode, the motor will not spin until the throttle percentage reached above 30% signal. Be sure you raise the throttle % high enough to start the motor spinning in this mode.
- Be sure to check the 3 x phase connections and ensure no issue with your soldering or connectors.
- The ESC may not run if the USB cable was plugged in during initialization. Please unplug the USB cable during initialization. You can plug it back in after the ESC has initialized.
- The ESC will not spin if protection functions are active. Check the log to ensure no protections are currently activated.

## 8. My ESC runs hot / keeps going into over temperature protection mode

- Check your ESC log, and ensure your maximum amp peaks are not higher than the ESC is rated for.
- Check your gear ratio / propeller choice, to make sure that you are not excessively loading the power system at low throttle percentages. This causes high phase current peaks, and may contribute to over temperature problems. More information about this topic in Section 11.1.
- Check your cooling and airflow to the ESC, and be sure to remove any straps or obstructions blocking the cooling fins.
- Be sure to use one of our Hi-speed cooling fans to your ESC.

### 9. Towards full power, my rpm seems to cut down drastically or be inconsistent

- Check your Log to ensure you are not pulling to many amps which is enabling the overcurrent protections of the ESC.
- Check your Log to ensure your battery voltage is not dropping excessively signaling a bad battery, or weak connection.
- Some high power/ high inductance motors, or motors with cheap quality materials, have prolonged demagnetization time periods which would lead to desynchronization. In these situations, to prevent desync, Tribunus limits power. Check your propeller / gear ratio to ensure your motor is operating within its limits. Try a smaller prop, or shallower gear ratio.

### 10. During / at the end of my flight, the RPM / Power cuts down to a lower power amount

- This likely is caused by the Protections being activated. Be sure to check the log to ensure no protections are being activated such as over temp, or battery capacity protection. (Section 10.0 for more information).

### 11. My ESC keeps shutting down while flying

- There is no function of the Tribunus ESC which will “hard cut” the motor during flight. If the motor stops in flight it is likely caused by an external factor.
- Check your motor and ESC phase connections. Ensure proper soldering. NOTE: That motor phase wires cannot be shortened! There is an enamel coating on the motor windings, which prevent solid soldering connection to be made even if it appears to be well soldered. If you have an inconsistent soldering connection, then it will cause the motor to stop spinning.
- Check your battery connectors for proper soldering.
- Check your BEC cables to ensure no cuts in the wires, or disconnection issues.
- Check your mechanics to ensure no issues with your drive train (one way bearing, loose prop, etc).

### 12. The capacity put back in my battery after charging does not match the amount the ESC telemetry says I used

- The capacity measurement of a Tribunus ESC is subject to quite a wide production tolerance in regards to the Capacity measuring.
- You can adjust the current measurement up to +/- 30% in Sproto Program under configuration tab / (E4) Current Measurement Adjustment.

### 13. The RPM displayed is not accurate

- Some radio systems do their own RPM calculations in the radio. So, you must enter specific settings in regard to the pole count / gear ratio in order for the 2 systems to work together. Please check documentation of your Radio / FBL system if this is needed.
- You must have the Pole Pair, and gear ratio entered in SPROTO setup, in order for the RPM to display a proper value in the log data.
- Be sure you have entered proper gear ratio.
- Be sure you have entered pole “pairs” not pole count in Sproto Settings.

### 14. Current displayed from the ESC compared to actual current (measured with an external amp meter) is different.

- The capacity measurement of a Tribunus ESC is subject to quite a wide production tolerance in regards to the Capacity measuring.
- You can adjust the current sensitivity gain up to +/- 30% in Sproto Program under configuration tab / (E4) Current Measurement Adjustment.

### 15. My motor acceleration seems slow (airplane mode) even if I lower the acceleration runup time

- Quick motor accelerations contribute to high phase currents, and prolonged de-mag time which may cause issues with your ESC.
- With our latest protections, if the requested acceleration is too fast for the ESC to safely handle, it will automatically slow down the acceleration time to prevent further issue.
- Change your propeller to a smaller / lighter one.

### 16. My Governor RPM is very inconsistent and overshoots all the time (Heli mode)

- This can happen when you have a mismatch of settings between the FBL system, and the Scorpion ESC. For example, if ESC is running Scorpion Internal Gov, and your FBL system is also running its own internal gov, then the 2 governors will fight against each other.
- Be sure your ESC and FBL unit, are both set so they are using compatible gov modes.

### 17. Is it important to update my ESC Firmware?

- **YES! Extremely Important!**

### 18. On my VBAR Control Touch Radio, I get constant RED WARNING SCREEN which tell me to land immediately

- If you see this warning screen you should of course adhere to the warning and be sure to check your model setup, and also your ESC log for any protection functions being activated.
- If the Warning continually happens at random, or when there is no actual protection issue, then it can only happen if there is a mismatch in your TX / ESC firmware. Be sure to update both your TX and your ESC to the latest firmware and the problem should resolve itself.

### 19. My ESC jumps straight to full throttle half way through the Slow Start Spool up (heli mode)

- Check value B9 – Governor Maximum RPM and make sure an appropriate value is set. See Section 8.0 for more details.
- Swap back to “Heli Gov – with Recalculated Maximum RPM”, Upload settings, then change again into “Heli Gov – with Prestored Maximum RPM” and try to upload settings again.

### 20. In Heli Governor Mode the maximum RPM is not high enough

- The maximum RPM of the governor system is auto calculated by the ESC. Depending on your motor or gear ratio, the calculated maximum RPM may be lower (or higher) then what the desired maximum RPM could be.
- If you want to manually set the maximum RPM of the governor, you can set it with value B9 – Gov maximum RPM.
- See section 8.0 for more information.

### 21. My Tail kicks during spool up (Heli mode)

- Be sure you have properly set acceleration values in the Heli Settings.
- Refer to Section 8.0 for more information about the various acceleration rates.

### 22. My ESC doesn't work now, makes only a "click" noise over and over

- The clicking noise signifies that the ESC is attempting to power up, but detects some fault, so therefore shuts back down again to prevent further damage.
- This means likely your ESC or motor has some issue and will need to be serviced.
- Please contact [support@spihk.com](mailto:support@spihk.com) or your local dealer for further assistance

### 23. The LED on my ESC / the BEC on my ESC doesn't power on

- If the ESC detects a fault, it will stop itself from powering on to prevent further damage.
- This means likely your ESC or motor has some issue and will need to be serviced.
- Please contact [support@spihk.com](mailto:support@spihk.com) or your local dealer for further assistance.

### 24. My capacitors are puffed, or were damaged in a crash. Can I fly it?

- **Absolutely not!** The capacitors act as a buffer to help stabilize the voltage going to your ESC. Operating the ESC with damaged capacitors will cause further damage.
- Please contact [support@spihk.com](mailto:support@spihk.com) or your local dealer for further assistance.

### 25. When I move my servos quickly my BEC shuts down

- Some servos create massive voltage spikes when operating which can trip the BEC protections.
- See **Section 1.6** for more information.

### 26. How can I adjust my ESC Timing or Frequency?

- **Note:** Tribunus has dynamic timing and frequency, so there is no user adjustment. The ESC sets it automatically and dynamically depending on the motor rpm and load.

### 27. My cooling fan is always spinning and not temperature controlled

- Pay attention to the plug orientation. If you plug the fan with the ground wire toward the switch symbol, it will be temperature controlled. If you plug the ground wire towards the ground (-) symbol, the fan will be always on.

## 18.0 Special Notes

### 18.1 Airplane with Reverse Mode - Throttle Calibration

In Airplane with Reverse Mode the point at which the motor rpm direction would reverse and the point which is for maximum "reverse" power needs to be set.

- 18.1.1 Be sure your ESC is set to "Airplane with Reverse Mode" in adjustment A2 – Device Mode
- 18.1.2 Turn on transmitter and power up receiver, then set throttle to maximum position, be sure that your throttle curve is set at 0% minimum throttle and 100% at maximum throttle.
- 18.1.3 Connect the battery to the ESC. After few seconds you will hear **one** beep. Now move your throttle to the lowest position (full reverse power) within a 3 second time period, then you will hear two beeps, then raise your throttle stick to the desired "zero" point (where the rpm direction would reverse), and you will hear another beep and then the POS Morse code come from the motor. This mean your calibration is done. You only need to do this once as throttle range will be stored in the memory of the speed controller. You can reset the throttle range by performing steps 18.1.1 to 18.1.3 again.
- 18.1.4 The endpoints and zero point can also be set manually in the configuration tab in parameter E6 – E8.

## 19.0 Importance of Proper Gearing (Helicopter use)

As a performance Brushless Motor and ESC manufacture, we feel it necessary to help teach our customers about the importance of proper gearing. Incorrect gearing can lead to higher battery and phase currents, which will degrade the performance of your model and may contribute to the premature failure of your Motor or ESC.

Most Helicopters rely on a Brushless motor, spinning very fast, and then use mechanical gearing to slow down the RPM to the disc. The motors have an optimal RPM, and amp loading range, and therefore need to be matched to the use case (disc size / desired RPM), by adjusting the motor kv, battery voltage, and pinion. If your gearing is out of range it can lead to a number of problems. A more basic example of this is to imagine going 20mph in your car while in 5th gear. Or vice versa, trying to go 70mph in 2nd gear. It will not work well!

If your gearing is too steep, then the motor is operating outside of its optimal efficiency rpm range, and additionally would lose its mechanical advantage. This would then require the motor to use what we call “brute amps” to try and push the motor through the load which you are using on it. This causes not only higher battery amps (which cause hotter running components), the compounding effect of this, is higher PHASE CURRENT peaks to your ESC. This is because since your motor is over geared, your ESC is having to drive the motor at partial throttle percentages, which internally raises even further your phase current amount. Read section 11.1 for more information.

**You may use our Scorpion Head Speed Calculator App to help you calculate your optimal Disc RPM. This app takes into account efficiency losses and also takes into account “headroom” for the governor to operate.**

[https://www.scorpionsystem.com/files/download/Scorpion\\_headspeed\\_calc\\_1.0.zip](https://www.scorpionsystem.com/files/download/Scorpion_headspeed_calc_1.0.zip)

**Example A (proper gearing)** | -700 disc size model, with HKII-4525-520kv motor, Tribunus II 12-130A ESC, 12 cell battery (44.4V) with 10.4:1 gear ratio. Using our Head Speed Calculator app, we can calculate the optimal RPM is 2030 rpm. Customer should fly highest rpm around 2030 rpm (which would pull around 130A peak), and can use lower throttle percentages and lower rpms while flying in a smoother manner.

**Example B (proper gearing)** | -700 disc size model, with HKII-4525-520kv motor, Tribunus II+ 14-200A ESC, 12 cell battery (44.4V) with 9.6:1 gear ratio. Using our Head Speed Calculator app, we can calculate the optimal RPM is 2150 rpm. Customer should fly highest rpm around 2150 rpm (which would pull around 180A peak), and can use lower throttle percentages and lower rpms while flying in a smoother manner.

**Example C (improper gearing)** | -700 disc size model, with HK5-5024-535kv motor, Tribunus II+ 14-200A ESC, 12 cell battery (44.4V) with 9.6:1 gear ratio. Using our Head Speed Calculator app, we can calculate the optimal RPM is 2300 rpm. Customer thinks the high kv and steep gearing will give “more power”, but it only runs 2000rpm. Customer uses 15%-20% lower throttle percentages to achieve 2000rpm but still flies in an aggressive way. Due to the improper gearing the motor is not in its optimal range and will pull higher amps (let us say 180A), then due to the partial throttle percentages, his ESC phase current could actually be over 220+ amps.

Customer should change pinion to smaller one, around 10.6:1 Gear ratio, and run 2100rpm with less collective pitch.

**Example D (improper gearing)** | -700 disc size light weight model, with HKIV – 4025 – 1100kv motor, Tribunus III 06-160A ESC, 6 cell battery (22.2V) with 10.8:1 gear ratio. Using our Head Speed Calculator app, we can calculate the optimal RPM is 2080 rpm. Since such a larger disc on low voltage would pull very high amps, customer thinks he can just lower the throttle percentage down to run lower RPMs. Customer uses 30-35% lower throttle percentages to achieve 1500rpm and flies in a moderate way. Due to the improper gearing the motor is not in its optimal range and due to the large disc it will pull higher amps (let us say 120A), but then due to the partial throttle percentages, his ESC phase current could actually be over 170+ amps.

Customer should use lower kv motor.

**Example E (proper gearing)** | -700 disc size light weight model, with HKII-4225-810kv motor, Tribunus II 06-120A ESC, 6 cell battery (22.2V) with 10.8 gear ratio. Using our Head Speed Calculator app, we can calculate the optimal RPM is 1530 rpm. Customer should fly highest rpm around 1530 rpm (which would pull around 100A peak), and can use lower throttle percentages and lower rpms while flying in a smoother manner.

**Example D (improper gearing)** | -570 disc size model, with HKIV – 4025 – 1100kv motor, Tribunus II 12-130S ESC, 7 cell battery (23.1) with 8.8:1 gear ratio. Using our Head Speed Calculator app, we can calculate the optimal RPM is 2600 rpm. Customer thinks using a 7s battery instead of 6s battery will give “less amps for equal power”, customer thinks he can just lower the throttle percentage down to run lower RPMs. Customer uses 20% lower throttle percentages to achieve 2300rpm and flies in an aggressive way. Due to the improper gearing the motor is not in its optimal range and due to higher voltage, it will be able to pull higher amps (let us say 160A), but then due to the partial throttle percentages, his ESC phase current could actually be over 175+ amps.

Customer needs to change gearing to ~10.1 : 1 to get the motor back into its optimal RPM range.

## 20.0 After Sales Service

Scorpion ESC are backed by a 1-year manufacture warranty. This covers defects related to manufacture production issues which have led to improper function or failure. The warranty does not cover user induced failures / damages. Examples of User induced damages include, but are not limited to, crashing, cutting the wires, capacitor connection failure (due to vibration / improper mounting), etc. Examples of User induced failures include, but are not limited to, improper gearing, poor motor choice, wrong disc / prop size, over current (see section 11.1) excessive battery wire length causing voltage ripple (see section 16), improper cooling / over temperature, improper acceleration settings, etc.

If you have questions or issues with your Scorpion Tribunus ESC, or would like to begin a warranty / repair claim, please contact the shop it was purchased from, or write us at [support@spihk.com](mailto:support@spihk.com).



Scorpion Power System LTD

Tribunus III (6 cell) Manual

Updated: August, 1<sup>ST</sup>,2024